

AUTOMATIC SUBMERGED SAFETY COVER



IMM'AX

Installation manual

Please read carefully and keep available for later use
02/2023 Version

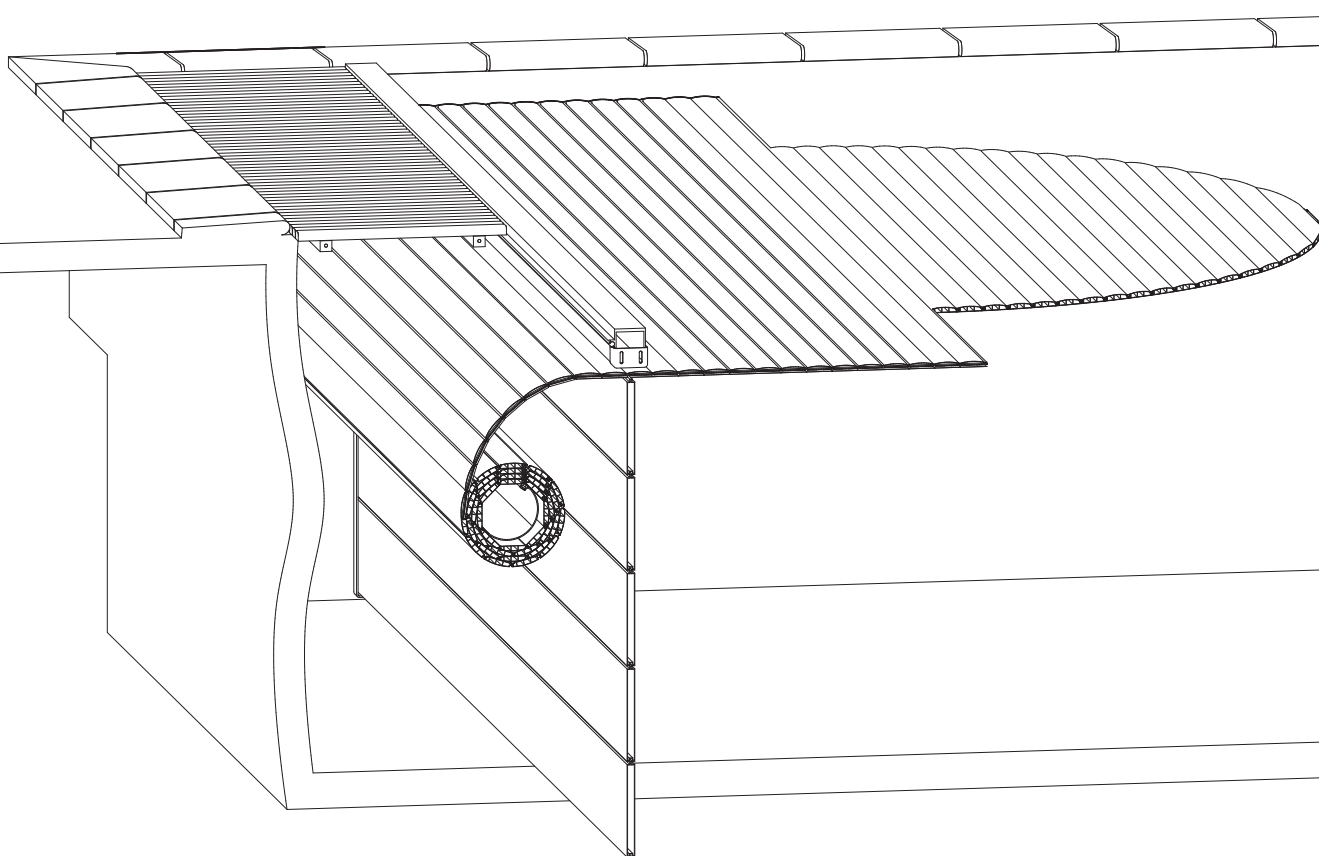

FOREWORD

This instruction manual is intended for the person who installs and commissions an ABRIBLUE automatic slatted safety cover within the scope of the catalogue for the current year.

This manual must then be given to the pool owner along with the safety and user instructions so that it is available for subsequent use.

The advice given in this leaflet is the result of AS POOL's experience in manufacturing automatic covers since 1995. It will allow users to make the best use of this product which should give complete satisfaction.

Compliant with the highest requirements, our safety cover was designed to prevent children younger than 5 years old from accessing the pool when it is unrolled and locked.



CAUTION
The floating slatted safety cover is not a substitute for your common sense or your responsibilities. It does not replace the vigilance of a responsible adult, which remains the essential factor in the protection of young children.



USEFUL ADDRESS

Your dealer (stamp):

CONTENTS

1. Preparing the pool	4
1.1 Electric connections and cable passages	4
1.2 Building work	4
1.3 Fitting the roller	5
2. Delivery and reception of the roller	6
2.1 Delivery	6
2.2 Reception	6
2.3 Items in the container	6
3. Assembling the roller	7
3.1 Necessary tools	7
3.2 Make the inventory compared to the order	7
4. Assembling the slats	11
5. Model with internal sensors - Type S box	12
5.1 Electric connections	12
5.2 Adjusting the limit switch stops	15
6. Model with internal sensors - Type U box	16
6.1 Electric connections	16
6.2 Adjusting the limit switch stops	20
6.3 INFO display	21
6.4 Troubleshooting table	21
7. Accessories and options	23
7.1 Bend prevention bracket assembly	23
7.2 Bend prevention bracket installation	23
7.3 High water level duck-board anti-bending bracket	24
7.4 Fixture on the edges	25
7.5 Chemical seals with insert	26
7.6 Positioning the fastenings for beams	27
8. Test instructions in the event of a malfunction	29
8.1 Box checks	29
8.2 Check your power supply cable between the box and the roller motor	29
8.3 Direct check of the motor	30
8.4 Checking the Bluetooth control box electronic board	30
9. Checks	30
10. Receipt of the slatted cover by the end customer	30
11. Appendix: troubleshooting assistance tool	31

1. Preparing the pool

1.1 Electric connections and cable passages

1.1.1 Electric box power supply

Fig. 1

- Prepare a 230 V power supply using an R2V 3G2.5 mm² (or Ro2V 3G2.5 mm²) cable for the electric box, which must be installed outside volumes ①, ②, and ③, and in a dry place (technical room).

Consult the current electric standards and in particular NF C 15-100.

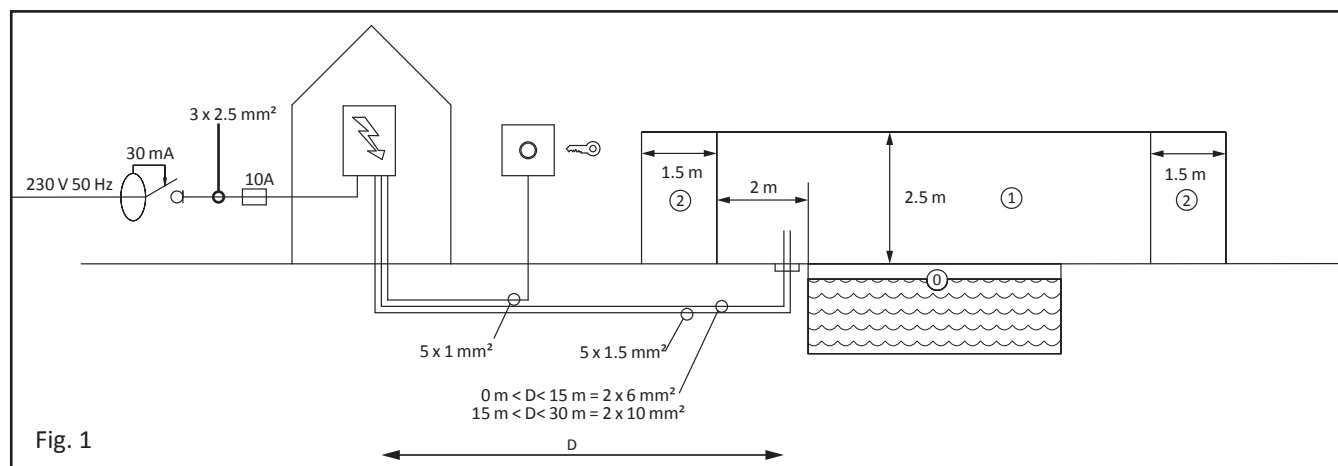

Fig. 1

1.1.2 Electrical protection

- This power supply must be protected by a circuit breaker or a 10 A fuse and a 30 mA ground fault circuit breaker.

1.1.3 Sheaths and cable passages

- Prepare a connection protected by a sheath for the 24 V DC power supply between the box and the junction box located near the roller using 2 x 6 mm² wire if the cable is less than 15 m long and using 2 x 10 mm² if the cable is between 15 m and 30 m long.
- Prepare a connection protected by a sheath for the limit switch management between the box and the junction box near the roller using 5 x 1.5 mm² wire.
- Prepare a connection protected by a sheath for the control between the box and the key operated Bluetooth control box using 5 x 1 mm² wire.
- Separate cables transporting different voltages (24 V and 220 V) and pass them freely placed in different protective sheaths and connect, removing all risks of oxidation and short-circuiting, and in watertight and accessible boxes located outside of volume 0 of the swimming pool as per the NF C 15-100 standard.

1.1.4 Earthing

- In compliance with the NF C 15-100 standard, it is imperative that all pools be fitted with earthing in compliance with standard requirements to evacuate any stray currents that would exacerbate metal oxidation phenomena.

- For a pool earth to be effective it must be properly sized and installed:

- Minimum 25 mm² copper braid.
- Earth rod pushed in by at least 1.2 m.

- Its value must be less than 20 Ohms to prevent corrosion phenomena and less than 100 Ohms in all cases for personal safety.

- Earth different from the home earth.

1.1.5 Cable exit

- Take out the connection cables from the box to the motor in the connecting box which is outside volume zero, between 40 and 80 cm from the pool and in the motor shaft alignment.

1.2 Building work

1.2.1 Concrete belt

Fig. 2

- Create a 0.37 m³ concrete block dosed at 350 kg/m³, 1.5 m long, 0.4 m wide and 1 m high.

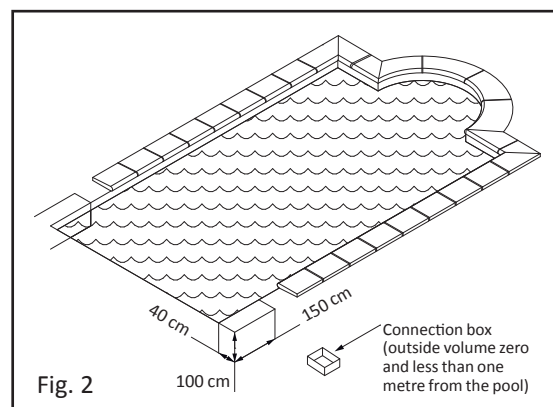

Fig. 2

1.2.2 Overflow

Fig. 3

- Plan to control the water level at between -10 cm and -15 cm below the levelling course using a \varnothing 50 mm overflow which is independent of the skimmers, and automatic filling. Take into account that when the cover is rolled-in it will raise the water level by 10 mm. The absence of an operational overflow compliant with our recommendations will void our guarantee.

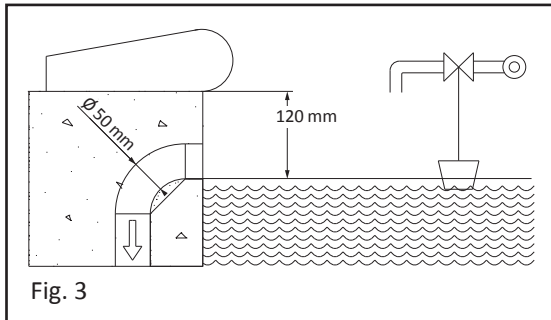

Fig. 3

1.2.3 Skimmers

- When possible, plan to place the skimmers on the pool widths and not on the lengths in order to facilitate the movement of the cover.

1.2.4 Water level regulator

- Provide a water-level regulator in the pool and in the technical pit in order to avoid any jamming, friction or distortion of the slats due to excess or lack of water.

1.3 Fitting the roller

1.3.1 Size of the trench

Pool length in m	D: Roller diameter (mm) Roller shaft included	F: Minimum width of the technical pit
4	420	480
5	440	500
6	460	520
7	480	540
8	500	560
9	530	590
10	560	620
11	580	640
12	590	650
13	620	680
14	640	700
15	660	720

Fig. 4

- Define the minimum width F of the roller pit using the following method:

- Determine the inner width allowing the complete rolling of the cover using the table. Take into account the radii, circular cuts and the thickness of a masonry partition wall that is wider than the beam, which would be unusable zones for fitting the cover.

- Check that:

If there is a duckboard laid on the pool levelling course:

$F < \text{Duckboard (in mm)} - 25 \text{ mm.}$

If a duckboard is covering the beam and laid on the levelling course:

$F < \text{Duckboard} - 25 \text{ mm} - 100 \text{ mm.}$

If a duckboard is not laid on the rear levelling course:

$F < \text{Duckboard} + \text{overlap of the coping.}$

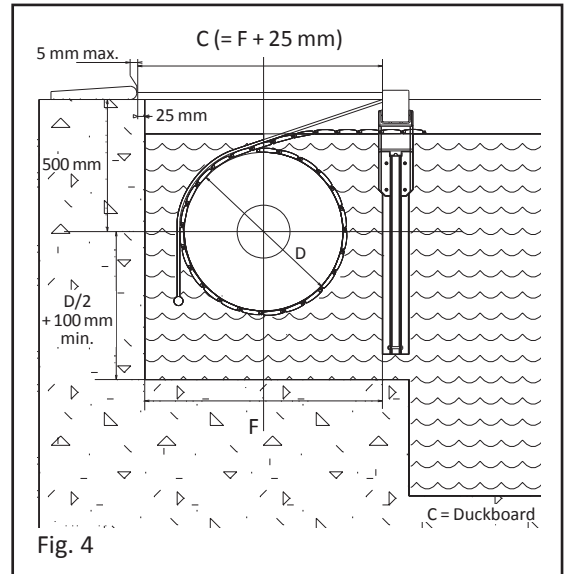

Fig. 4

1.3.2 Squaring checks

Fig. 5

- In order to correctly place your roller perpendicular to the pool lengths: measure the diagonals.
- Make a mark (1) on the pool liner at the level of the edge at the centre of the rolling trench.
- Measure a precise length "A" of 1 m less than the length of the pool and make a mark (2), at the end of A on the pool liner.
- On the opposite length make a mark (3) opposite mark (1).

Important, items 1 and 3, while complying with squaring, must be located as close as possible to being plumb with the rear coping edges for right angles, or the end of any eventual curve.

- Carry over the "A" measurement from (3) in order to place mark (4).
- Measure the distance "B1" between (1) and (4) and measure the distance "B2" between (2) and (3).
- If B1 and B2 are equal continue with the next step, otherwise correct the position of marks (3) and (4) and start the operation again until $B1 = B2$.

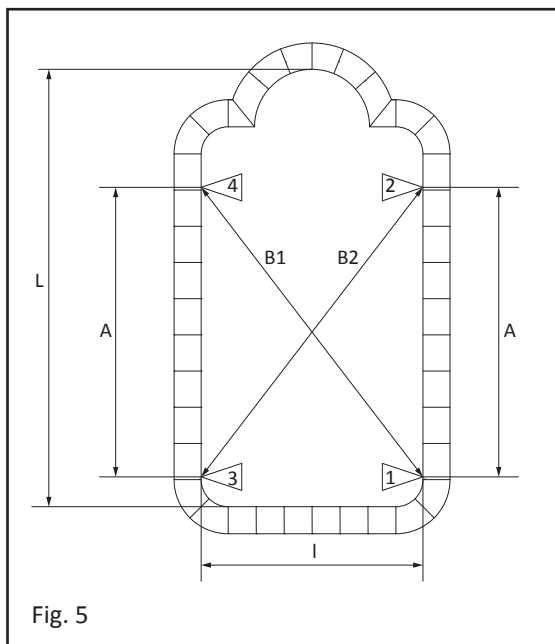

Once this test has been carried out and checked, points 1 and 3 will be used as references to align the shaft to the pool. This positioning enables the shaft to be perfectly perpendicular to the length of the pool.

2. Delivery and reception of the roller

2.1 Delivery

Fig. 6

- Plan the presence of 2 to 6 persons, or use a handling device to handle the cover. The cover is delivered in a non-recoverable wooden container measuring at least 40 cm more than the width of the pool. It is heavy and fragile.
- For a 4 x 8 m pool, the container weighs 465 Kg and measures 4.6 x 0.6 x 0.8 (h).
- For a 5 x 10 m pool, the container weighs 610 Kg and measures 5.6 x 0.6 x 0.8 (h).

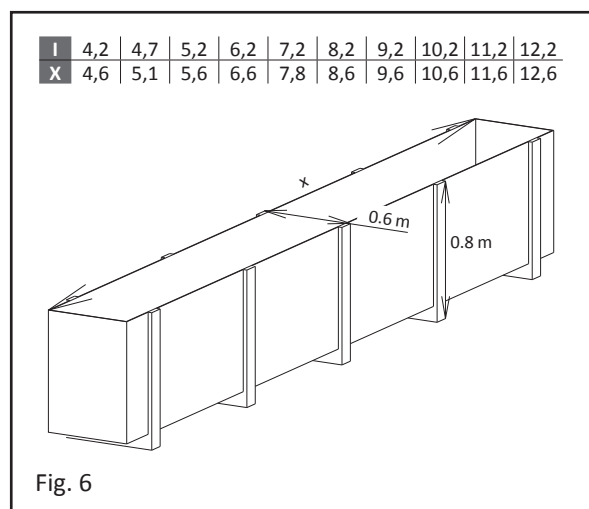
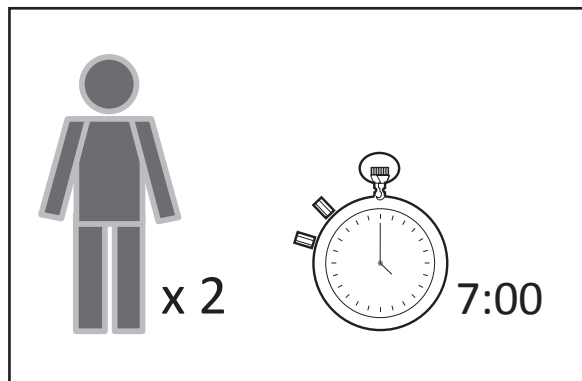

Fig. 6

2.2 Reception

- Open the container in the presence of the delivery staff and check the condition of the goods and their compliance. Keep the original packing.
- If there is any damage or missing parts, write down your reserves on the transport documents (e.g.: container open on delivery). The words "subject to unpacking" alone are null and void. Send a registered letter (with acknowledgement of receipt) to the transporter within 2 days. This letter must accurately detail the damage found. Send a copy of the letter to AS POOL for information.
- Store the parts in the container which should not be left in full sunlight, but should be placed in a cool place if the assembly is not carried out on the same day.
- Make the inventory compared to the order.
- Read the instructions completely before starting the assembly.
- The installation requires 2 persons for 7 hours.



2.3 Items in the container

- A slatted cover.
- A motorised roller shaft.
- Two flanges to support the roller shaft.
- A 23 x 32 cm box.
- A cover protection made up of a beam and duck boards (if ordered).
- A partition wall (if ordered).
- A fixture kit.
- Installation instructions.

3. Assembling the roller

3.1 Necessary tools

Fig. 7

- Plan the equipment necessary for assembly: a perforator, a set of spanners, socket wrenches and hex keys, a set of screwdrivers, a mallet, pliers, a level, a glue gun, a cutter, a multimeter, a tape measure, a saw, an angle grinder and a marker.

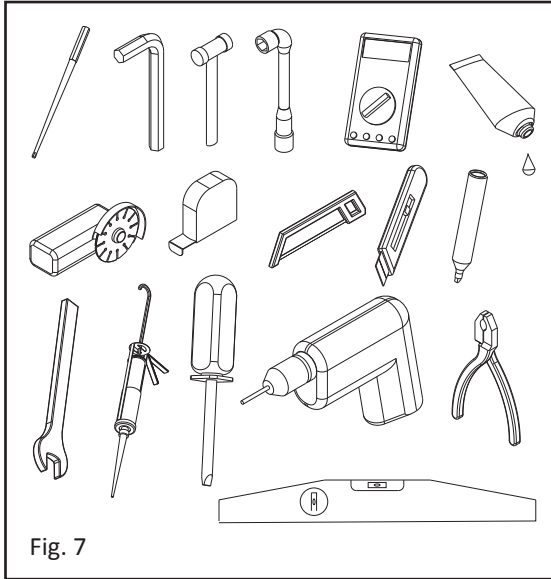

Fig. 7

3.2 Make the inventory compared to the order

Warning: at each step check that the roller can be installed horizontally on a level and square.

3.2.1 Drilling the walls

Fig. 8

- Use the flanges as a template to mark the fixtures using marks 1 and 3 to place the equipment (Fig. 5).

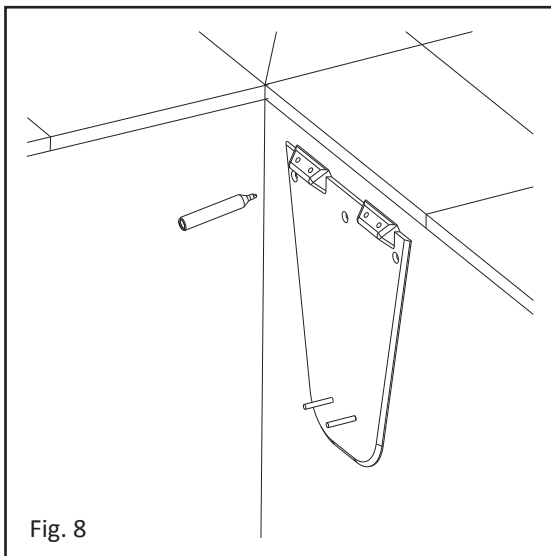

Fig. 8

Fig. 9

- Drill the wall horizontally according to the marking with 12 mm diameter holes of 70 mm depth, using a wireless drill.

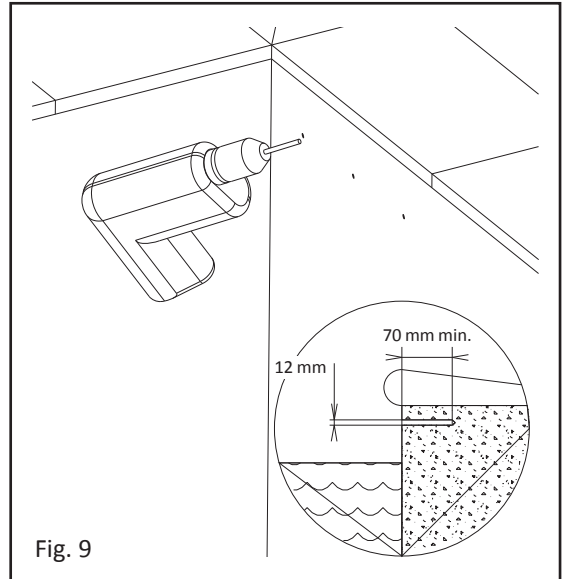

Fig. 9

CAUTION:

The notion of wireless drill is **HIGHLY IMPORTANT**, it means a battery powered drill. A hard-wired drill is connected to the mains, i.e. to 220 V, which is dangerous and strictly prohibited in this situation.

3.2.2 Assembling the shaft and the end casing

Fig. 10

- Assemble the motorised tube to the flange on the side opposite the motor following these steps:

- fit the stop ring to the bearing shaft which is used to stop the bearing shaft from sliding,
- fit the black bearing to the bearing shaft,
- fit the $\varnothing 8$ pin into the shaft and slide the black bearing to hold it by covering the pin and the end of the shaft,
- fix the black bearing to the bearing flange using M10 nuts. Thus the pin is trapped in the black bearing against the flange.

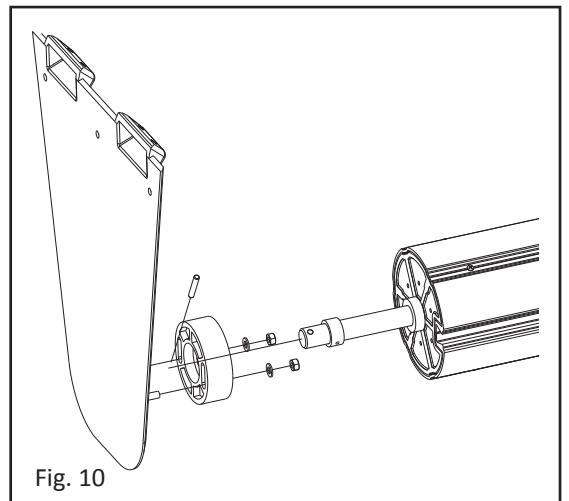

Fig. 10

Fig. 11

- Assemble the motorised tube with the flange on the motor side by inserting the motor end into the conical black bearing.
- Pin the motor end to the bearing shaft using the pin (stainless steel ring diameter 10 mm) making sure that the pin crosses the motor shaft completely.
- Pass the motor cable behind the central embossing of the flange between the pin and the pool and bring it out in the upper part of the embossing.
- Fitting the roller.
- Fit the TFHC M10 x 60 screws and gaskets.
- Disconnect the motor cable. The cable must be free from constraints.

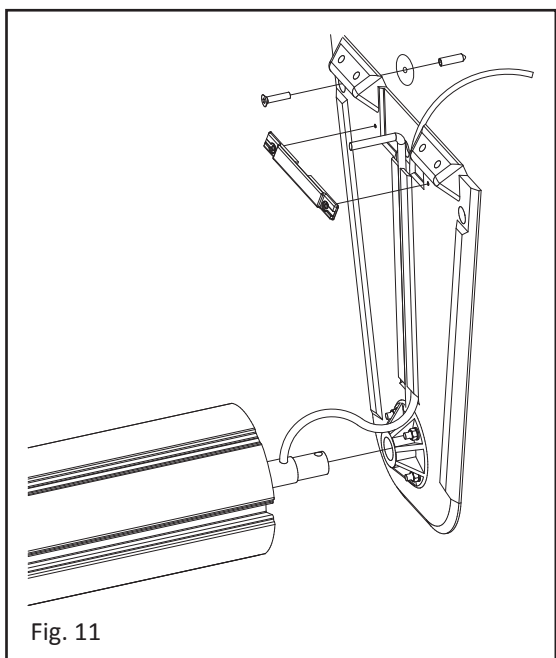

Fig. 11

3.2.3 Installing the roller

Fig. 12

- Slide the bearing shaft into the tube to shorten the whole.

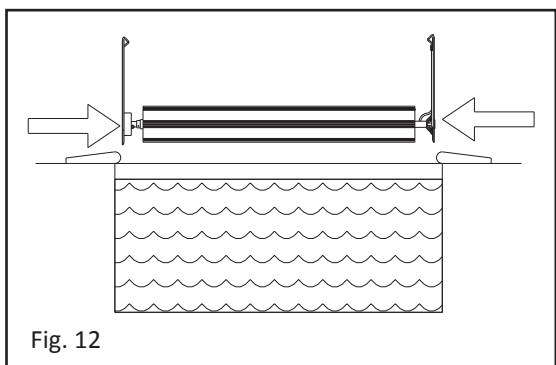

Fig. 12

Fig. 13

- Lower the assembled roller into the pool.

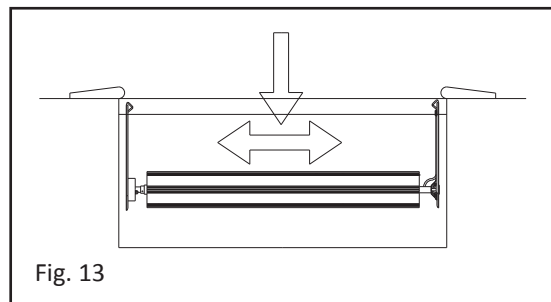

Fig. 13

Fig. 14

- Strike the TFHC M10 x 60 screw heads using a mallet in order to insert them into the concrete belt.
- Tighten and check the solidity of the fixings.

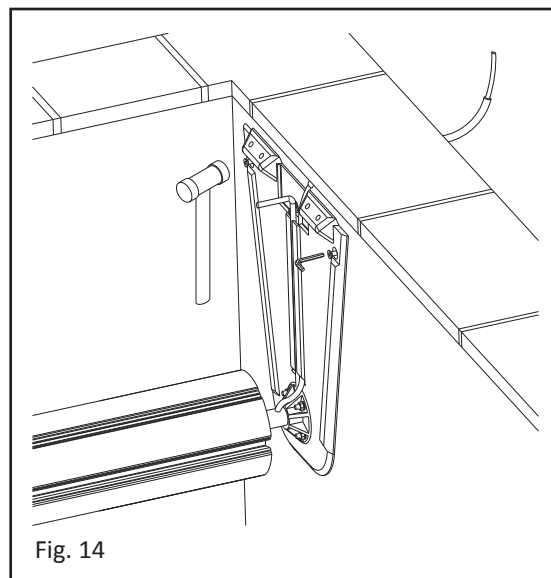
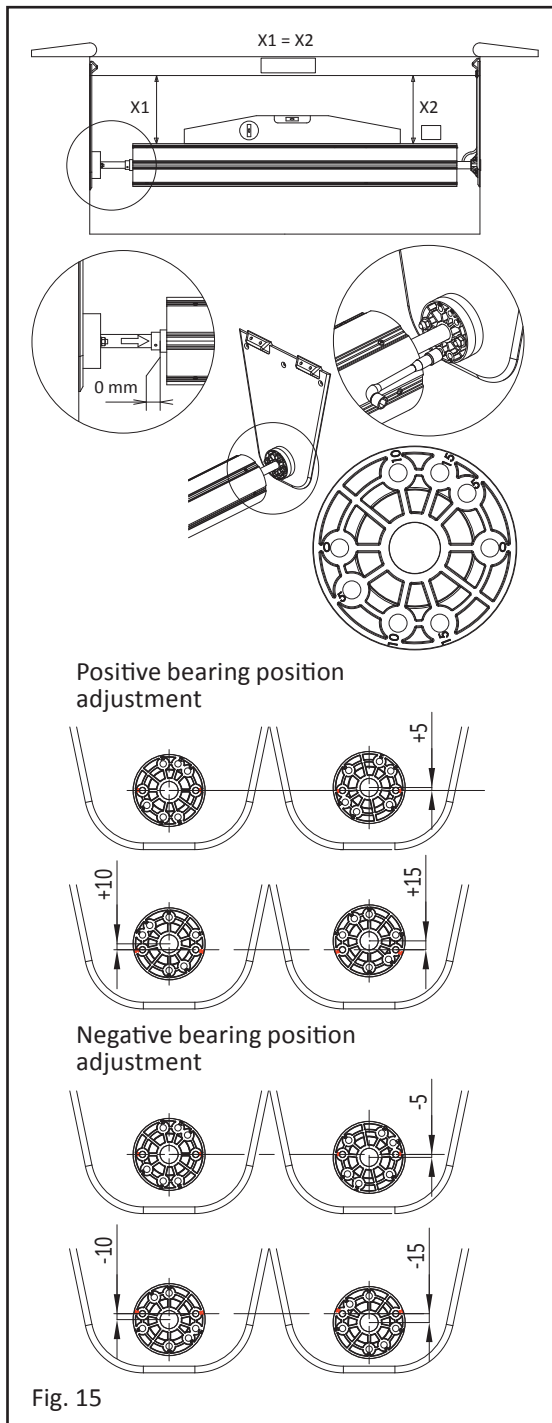

Fig. 14

Fig. 15

- Push aside the two flanges so that they touch the walls of the pool, place the blocking ring against the drive ring of the tube then securely tighten the screws on it.
- Place the bearing on the 0 and check that the roller shaft is horizontally level.
- If the roller shaft is not level when on the 0 position, adjust the bearing to the different 5, 10 or 15 positions to raise or lower the roller shaft by the indicated value.
- The bearing tightening torque must be 20Nm.
- Check the level of the shaft at each end using a tape measure, measurement X1 should be equal to X2.



3.2.4 Place the sliders and beam boxes

- Place the centre of the wall sliders using the F measurement plus 50 mm (see page 5).
- Check using the beam box that the position allows the bottom of the duckboards to be level with the edge or the duckboard support and that it is correctly placed lengthwise.

Fig. 16

- Make the markings on the side of the pool.

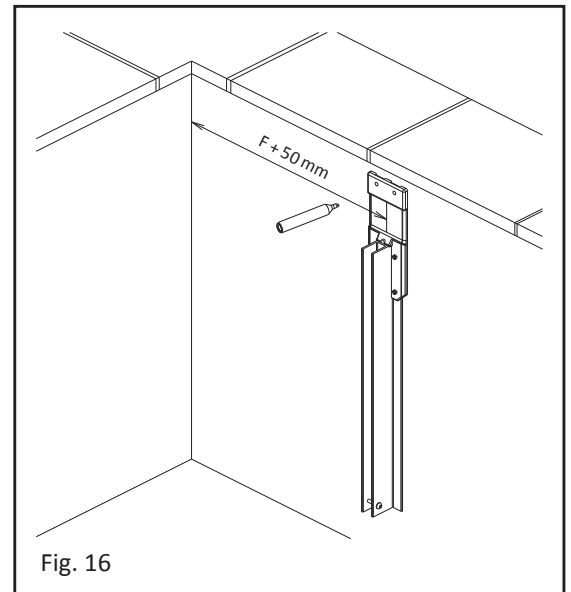
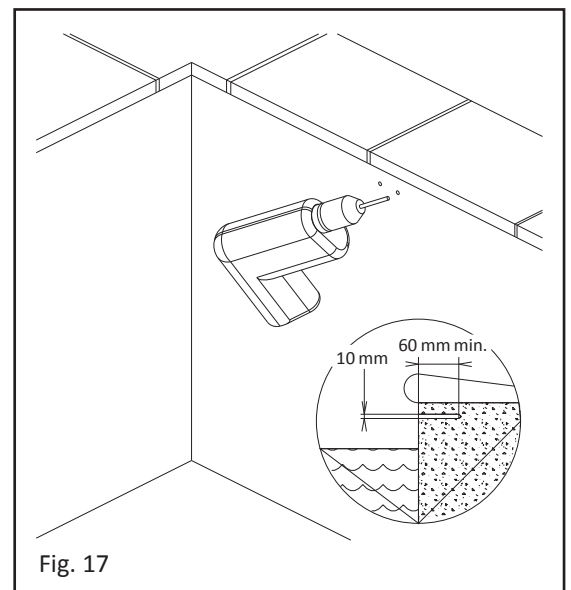

Fig. 17

- Drill the sides at the markings using a 10 mm bit for a depth of 60 mm.
- Fit the TFHC M8 x 55 screws on the sliders.



3.2.5 Install the partition wall and beam

Fig. 18

- Disconnect the motor cable. The cable must be free from constraints.
- Install the sliders and the beam boxes or only the boxes if the trench divide is in masonry.

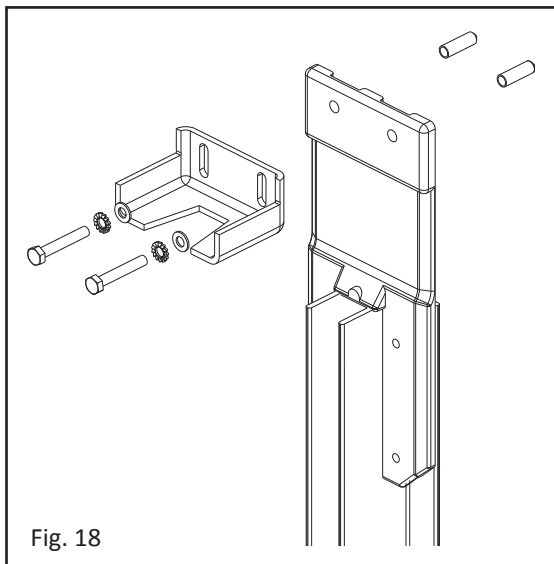

Fig. 19

- Strike the TFHC M8 x 55 screw heads using a mallet in order to insert them into the concrete belt. Placing the roller.
- Adjust the height of the beam boxes depending on the height of the beam, so that the lower side of the duckboards is level with the edge and that the duckboard is supported by the side support of the beam.

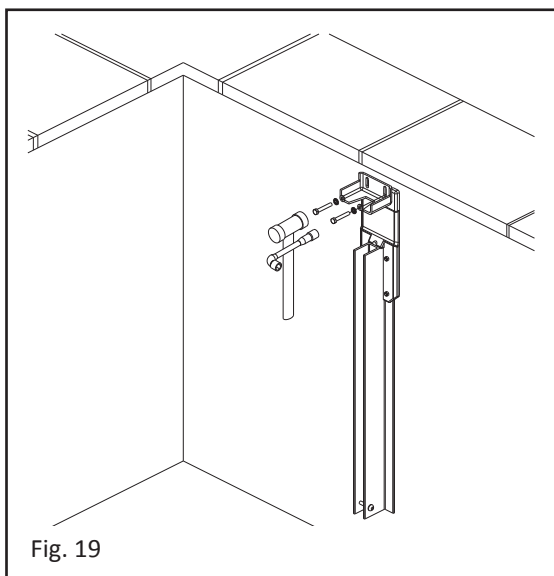

Fig. 19

Fig. 20

- Assemble the side wall panels by clicking them together by placing them flat side by side and hitting them with a mallet protected by a wooden wedge from one end to the other.

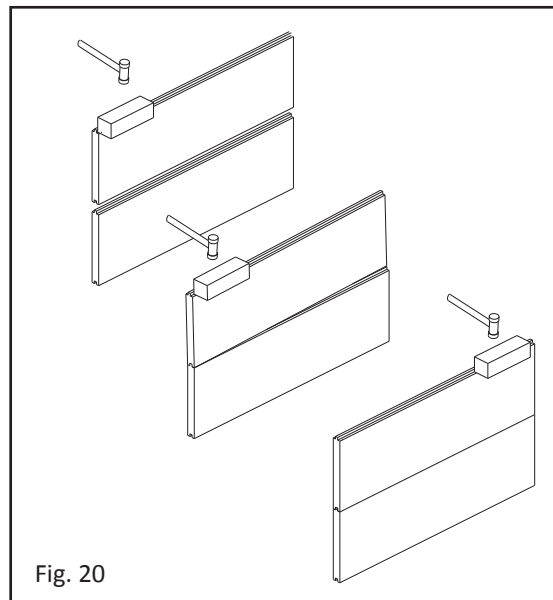

Fig. 21

- Lower the partition wall into the pool.
- Insert the finishing "U" in the last partition wall.
- Fix the "U" using stainless steel TR 4.8 x 13 PZ screws.

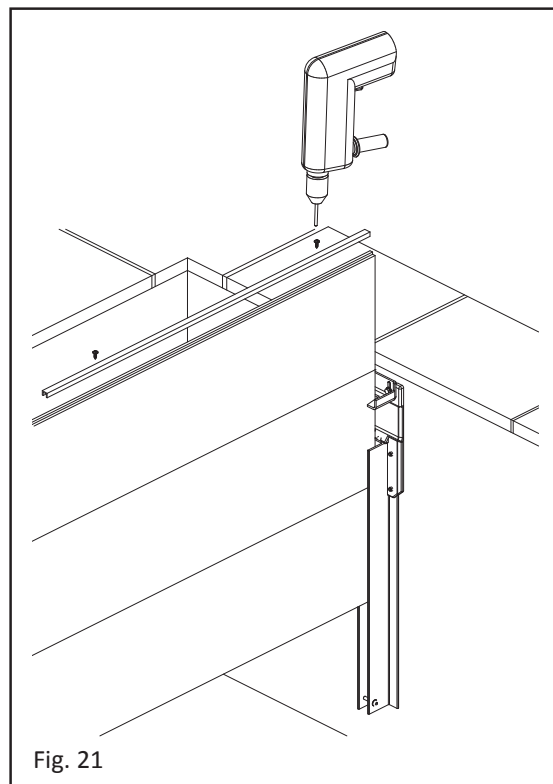

Fig. 21

Fig. 22

- Place the beam into the boxes making sure that the end of the beam can never have less than 4 cm on each box.

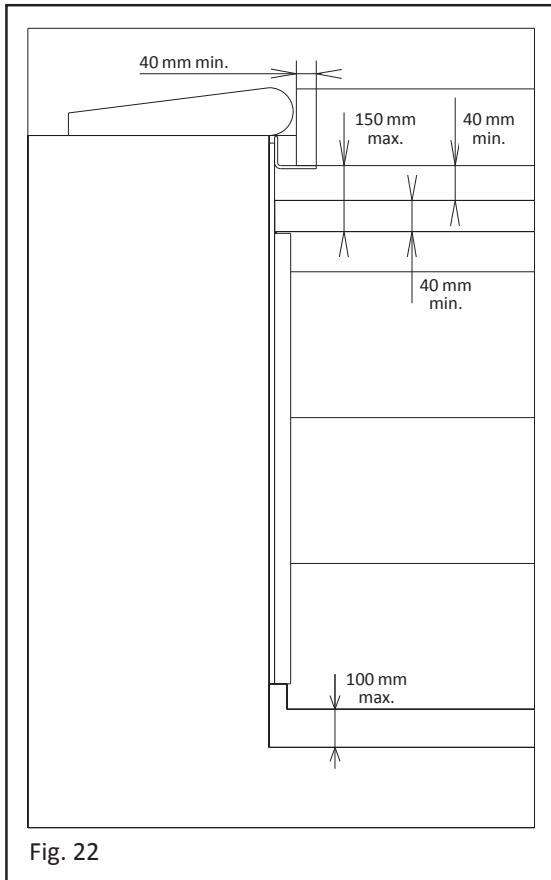

Fig. 22

Fig. 23

- Slide the white cylindrical cabiclips of the bungee cords into the groove in the beam.
- Thread the counterweights onto the bungee cords and spread them evenly over the width of the pool.
- Check the length adjustment of the bungee cords so that the counterweights are at least 5 cm from the bottom of the pool when the cover is unrolled.

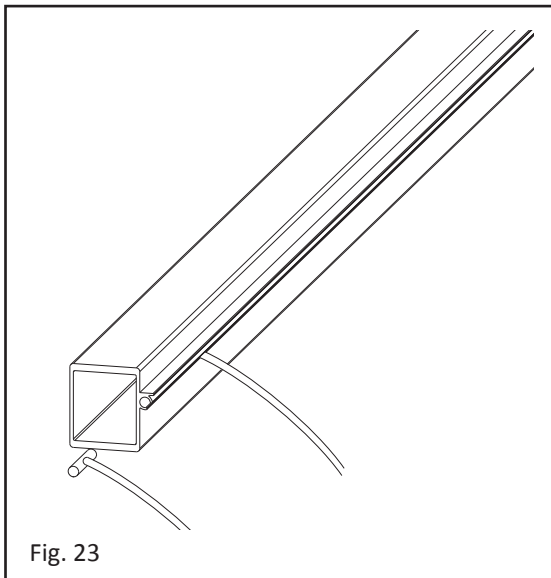

Fig. 23

3.2.6 Installing the duckboards

- Carry out the electric connections, the cover assembly and the end of stop adjustments before installing the duckboards.

Fig. 24

- Assemble the duckboard walkway so that each independent element weighs at least 10 Kg/part (approx. 1 m²):
 - Wood duckboards are assembled by side slotting using cylindrical anchors,
 - Aluminium duck boards are assembled by longitudinal slotting and are prevented from moving using the headless screws,
 - PVC duck boards are clipped together by striking the side with a mallet and a wooden block when they are laid side by side (from one end to the other),
 - When the cover is installed and the operating tests are complete, fill the junction box with waterproofing gel to limit the oxidation of the connections which may cause malfunctions.

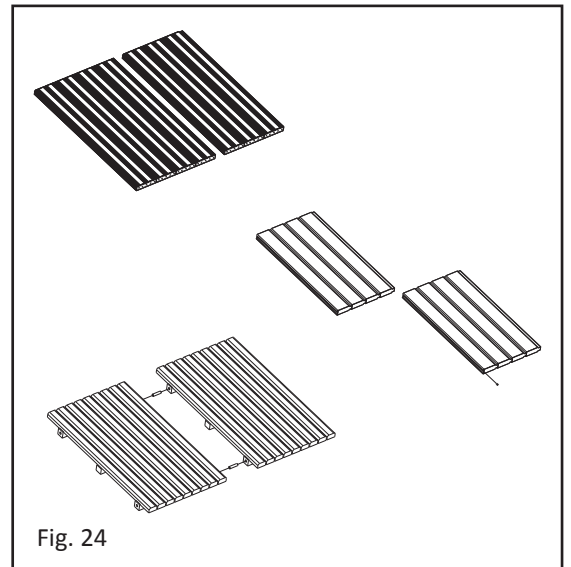

Fig. 24

4. Assembling the slats

Please refer to the "Slat cover" instructions.

5. Model with internal sensors - Type S box

Important, take the jumper from the bag and insert it on the C+ on the Bluetooth box board. Otherwise the key-operated control will not work.

5.1 Electric connections

- Have the electric connections made by a qualified technician in compliance with current standards.
- Fix the transformer box in the technical room.
- Install the Bluetooth control box so that the cover can be controlled while having a permanent view over the pool.

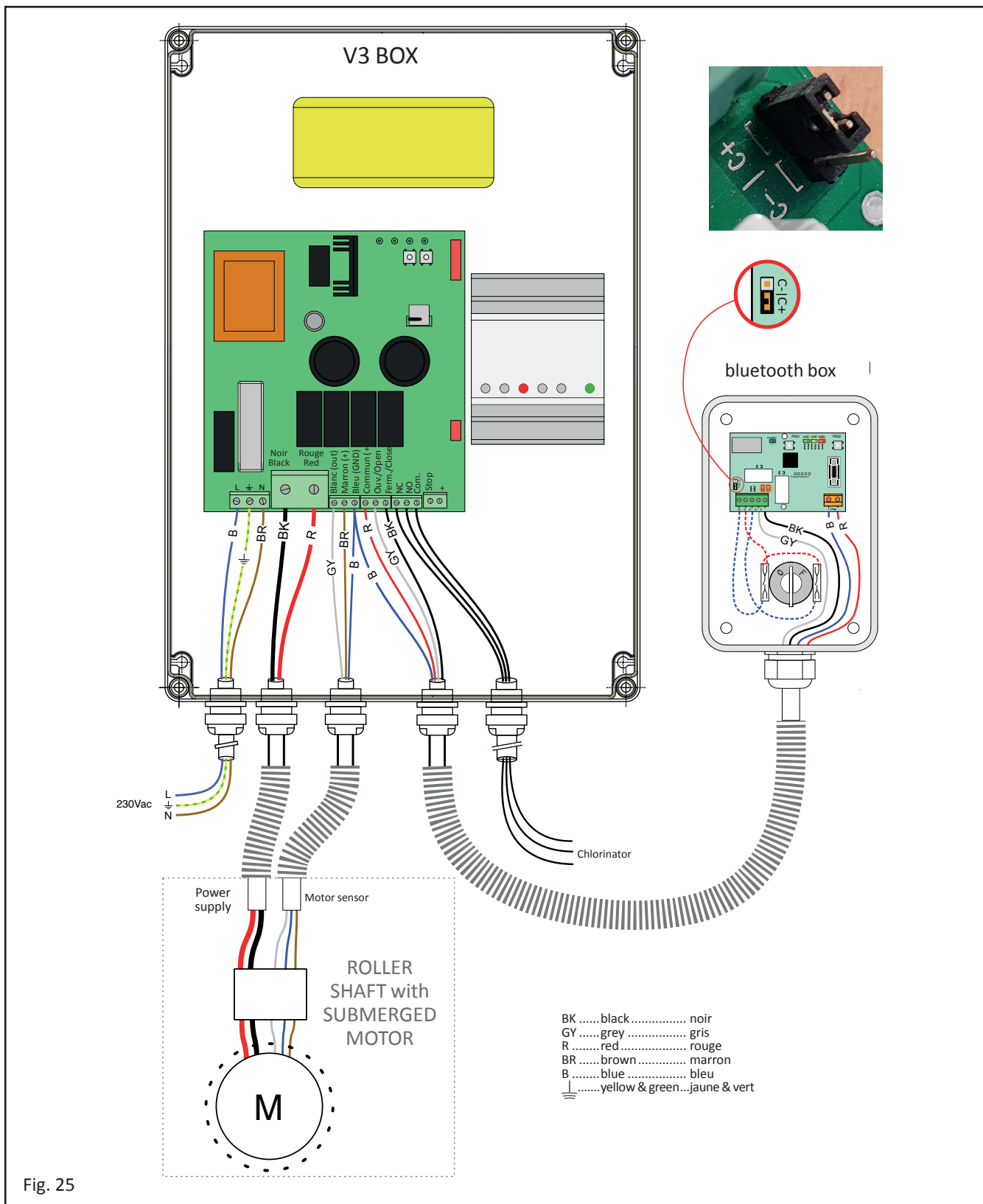

Fig. 25

- Place the Bluetooth control box cable gland towards the bottom.
- All the connections and disconnections must be made when the power is off.

5.1.1 Box

Fig. 25

- In the box, connect the 230 V power cable to the screw terminal to the left of the terminal blocks respecting the "⏏", "L" and "N" symbols.
- In the box, connect the motor power wires of the connecting cable to the "ROUGE" (RED) and "NOIR" (BLACK) terminals taking care to respect the colours of the motor cable wires.
- In the box, connect the motor sensor wires of the connecting cable to the "CAPT" terminal block (terminals 1, 2 and 3 marked "WHITE" "BROWN" and "BLUE" taking care to pair the colours with those of the motor cable wires.
- In the box, connect the Bluetooth control box wires to the "CAPT" terminal block". (Terminal 3 marked "blue" = double of the motor sensor wire) and the "CLE" terminal block (terminal 4-5-6) marked "COMMON" "OPENING" "CLOSURE".
- Connect the treatment appliance to the "Info terminal block,:(terminals 7 or 8 and 9 marked "NC", "NO" and "COMMON" if you chose to use this function.

5.1.2 Bluetooth control box

The Bluetooth control box is a control component for automatic covers.

It is composed of a key-operated switch and a Bluetooth receiver board that can communicate with a terminal running the IOS10 or Android OS5 operating systems on which the "AERO" app is installed.

5.1.2.1 CONTROL BOX DESCRIPTION

Fig. 26

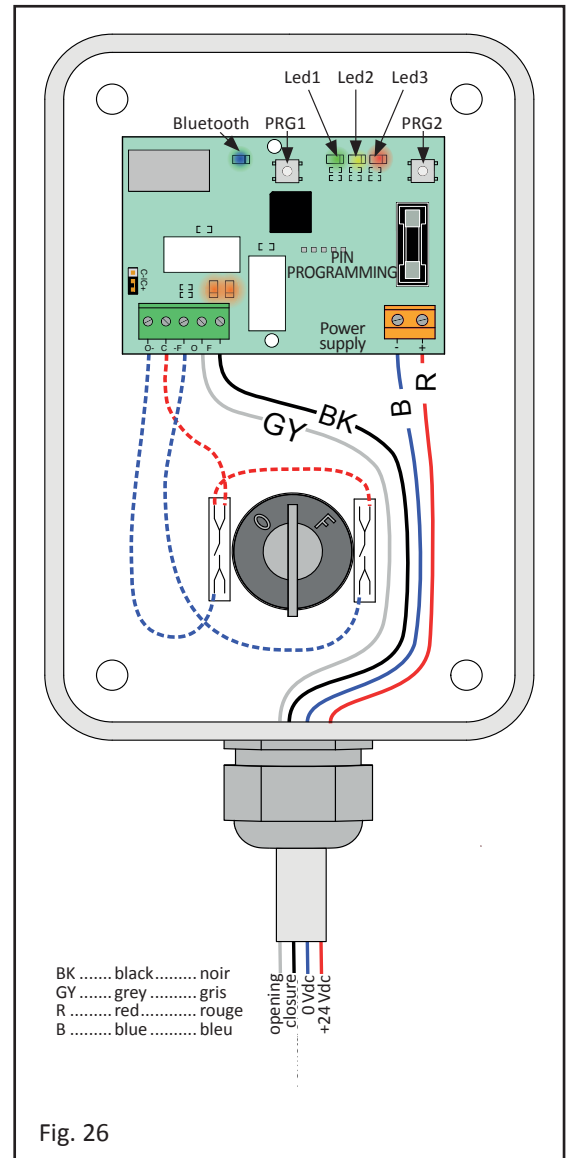

Fig. 26

Key operated box with board diagram

- The electric board has a 24 V DC power supply on the "+" and "-" terminals". The board also operates using 12 V direct current, the connections remain the same and the 24 Vdc notes should be read as 12 Vdc.
- The open/close commands are on the O/F terminals. The C terminal corresponds to Common.
- The key-operated switch is connected in parallel (remember to remove the key after each use).

Setting

- In "Continuous press "mode, action on the key-operated switch or the smartphone button is required for the cover to move. Releasing the control will stop the movement.

- In "press" mode, an action on the key-operated switch or the smartphone button will cause the cover to move. To stop, operate the key-operated switch in the other direction or press one of the Stop opening or closure buttons (or press the button again), otherwise the movement will stop at the motor limit switches.
- There are 3 operating modes with 3 viewing LEDs on this receiver:
 - Led 1 (green) default mode: continuous press for closure, single press for opening (compliant with the NF P90-308 standard).
 - Led 2 (orange) mode: single press mode for closure, single press mode for opening. CAUTION: this mode is PROHIBITED in France (not compliant with the standard).
 - Led 3 (red): continuous press for closure and opening (compliant with the standard).
- Switching from one mode to the next on the board: Press the PRG2 button until the 3 LEDs all flash at the same time. Then scroll through the modes by pressing PRG2. The LED flashes on the selected mode. Exit the mode by pressing PRG2 for a long time until the LED stays on without flashing.
- Reset to 0: Press the PRG1 button to turn reinitialise the board.

Box wall mounting

- Fix the control box to the wall using the supplied anchors and screws using the fixing holes provided.
- Position in a location sheltered from the elements, where there is a clear view of the pool, less than 15 m from the pool and without any obstacles between the control box and the smartphone that could interfere with the signal.

5.1.2.2 INSTALLING AND COMMISSIONING THE AERO APP.

WARNING: Never use the manual control and the remote control (using the app) at the same time as this may put the cover components out of order.

Compatible devices

- Apple® iPhone® smartphones running iOS 10 or later version operating systems.
- Other smartphones running Android® OS 5 versions or later operating systems.
- Any terminal that has the above operating systems.

Installing the AERO app

- Download the "AERO" app from App Store or Google play.
- The links can be obtained directly using the QR codes on the manual cover page and on the control box.

Commissioning the AERO app

- Check that the control box is powered on.
- Make sure that Bluetooth and geolocation are enabled on your smartphone or other terminal.
- Launch the app and follow the instructions.
- To pair the phone with the cover, enter its 4 digit code but only the first time (The code is on the manual cover page and on the electronic board).

5.1.2.3 CONNECTING THE CONTROL BOX TO THE COVER

Connect the wires as shown in figure 25.

REMINDER: Invert the wires connected in the box on "OUVERTURE" (OPEN) and "FERMETURE" (CLOSE) if the cover movement does not correspond to the "OUV." (OPEN) and "FERM." (CLOSE) indications on the grey plate of the key-operated switch or the "OUVRIR" (OPEN) and "FERMER" (CLOSE) buttons in the AERO app.

5.1.3 Connection box

Fig. 27

- Plan M27 or M32 cable glands if you use 2 x 10 mm² cable.
- In the connection box, connect the power and sensor wires strictly respecting the colour codes "ROUGE" (RED), "NOIR" (BLACK), "BLANC" (WHITE) "BRUN" (BROWN), and "BLEU" (BLUE) on the box card and the colours of the motor cable wires.
- Use the screw terminals provided for these connections.
- When the cover is installed and the operating tests are complete, and once the limit switch settings are finished, fill the junction box with waterproofing gel to limit the oxidation of the connections which may cause malfunctions.
- The connection box must be 50 cm outside of the volume 0 (see fig. 1) and accessible at any time.

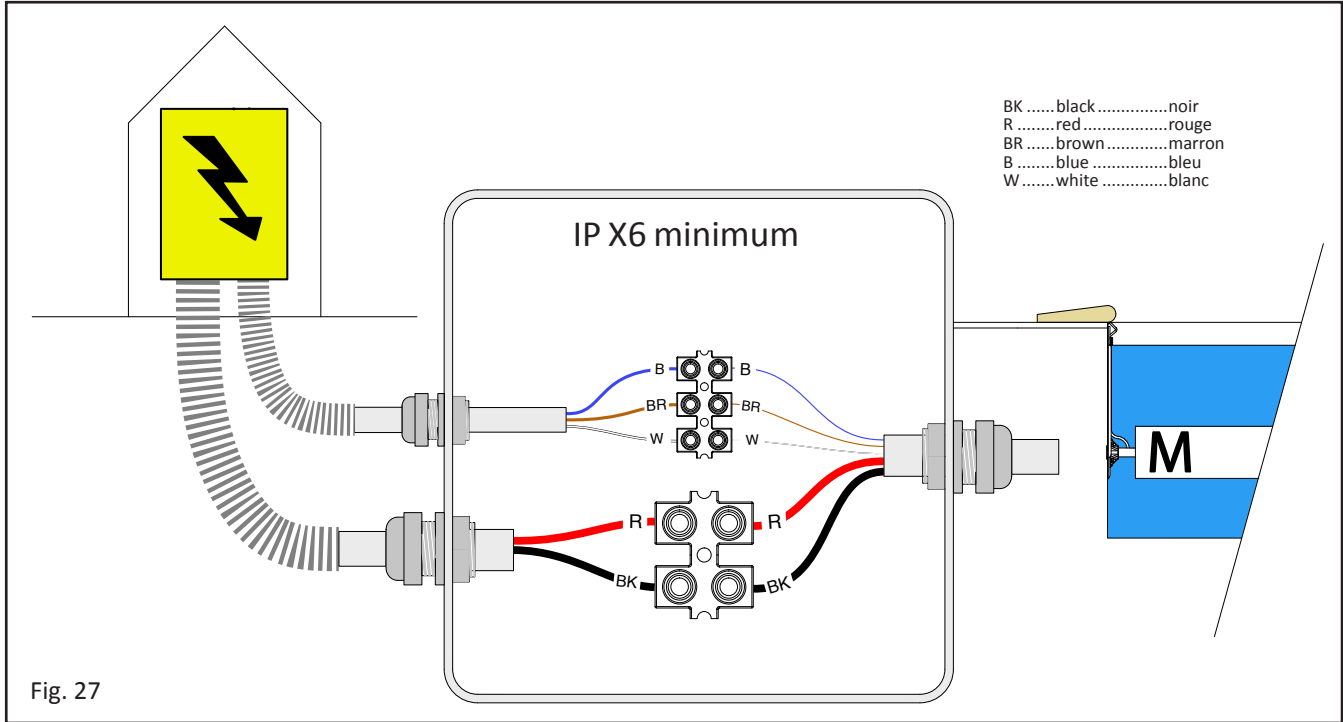

Fig. 27

5.2 Adjusting the limit switch stops

- Switch on the box.
- Switch to AUTO mode.
- Press on "A" to activate the system.

Fig. 28

- Initialise by pressing 3 times on "+" and then once on "OK".

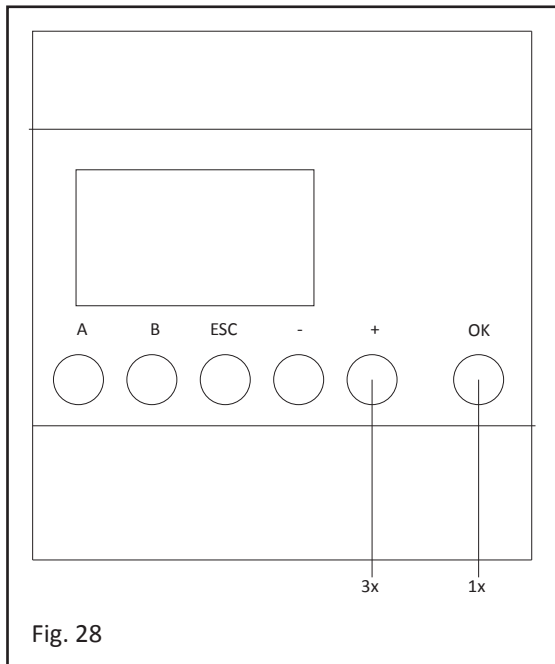

Fig. 28

Fig. 29

- Indicate the motor position by placing yourself above the roller with your back to the pool: • Press once on "+" if the motor is to the right • Press once on "-" if the motor is to the left.

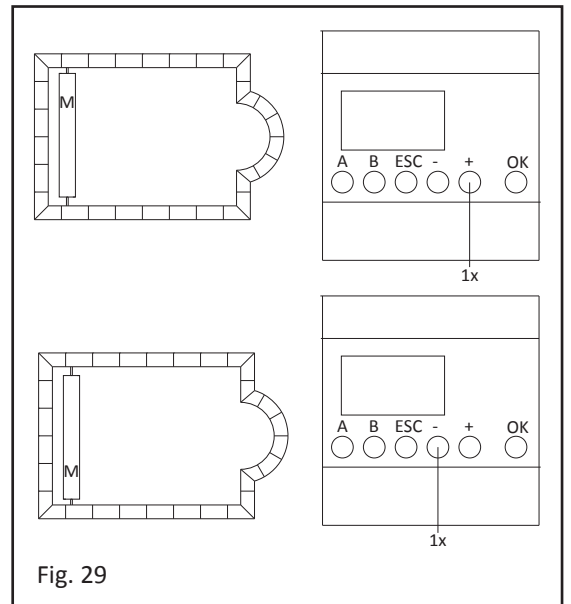

Fig. 29

Fig. 30

- Using the control key, unroll the cover and validate the position by pressing "A" once.
- The PLC indicates that it has taken into account the position by displaying an "M" next to "closed pos".

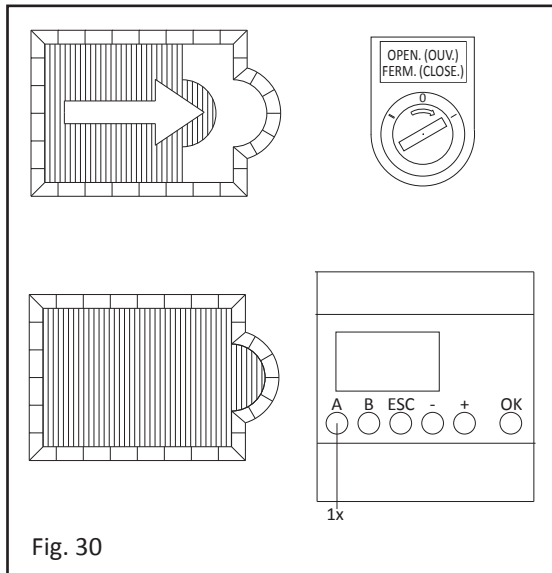

Fig. 30

Fig. 31

- Using the key, roll in the cover and validate the position by pressing B once when rolling in is complete.
- The PLC indicates it has taken into account the position by displaying "stop".
- Restart at the initialisation step: Press 3 times on the + key, then on "OK" if you wish to reprogramme.
- Invert the wires connected in the box on "OUVERTURE" (OPEN) and "FERMETURE" (CLOSE) if the cover movement does not correspond to the "OPEN. (OUV.) FERM." (CLOSE) indications on the key-operated switch.

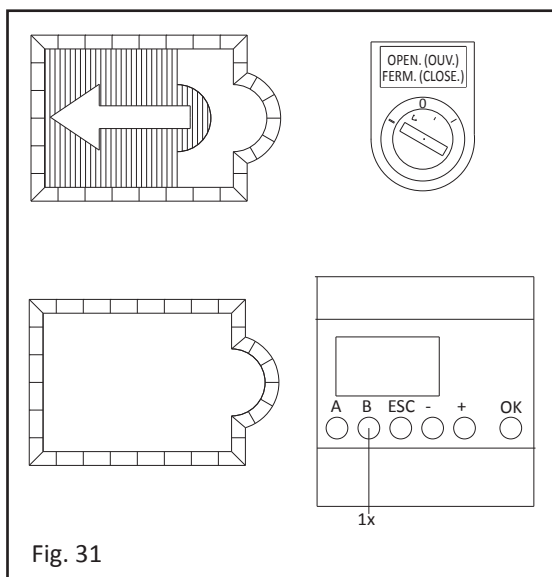

Fig. 31

6. Model with internal sensors - Type U box

Important, take the jumper from the bag and insert it on the C- on the Bluetooth box board. Otherwise the key-operated control will not work.

6.1 Electric connections

- Have the electric connections made by a qualified technician in compliance with current standards.
- Fix the transformer box in the technical room.
- Install the Bluetooth control box so that the cover can be controlled while having a permanent view over the pool.
- Place the Bluetooth control box cable gland towards the bottom.
- All the connections and disconnections must be made when the power is off.

6.1.1 Box

Fig. 32

- In the box, connect the 230 V power cable to the screw terminal to the left of the terminal blocks respecting the "L", "N" and "N" symbols.
- In the box, connect the motor power wires of the connecting cable to the "ROUGE" (RED) and "GRIS" (BLACK) terminals taking care to respect the colours of the motor cable wires.
- In the box, connect the motor sensor wires to the "SENSOR" terminal block marked "OV" for the "BROWN" wire and "IN" for the "BLACK" wire taking care to match the colours with the motor cable wires. The "BLUE" wire is not connected.
- In the box, connect the Bluetooth control box wires to the "SENSOR" terminal block marked "OV" for the "BLUE" wire doubled with the motor sensor "BROWN" wire and the "V" with the "BROWN" wire, and on the "KEYS" terminal block marked "CL" for the "BLACK" wire and "OP" for the "GREY" wire.
- Connect the treatment device to the "AUX" terminals marked "NC" or "NF", and "CC" if you choose to use this function.

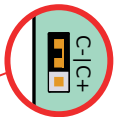
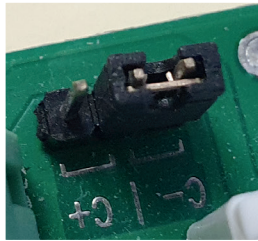

IMPORTANT: jumper to be placed on C

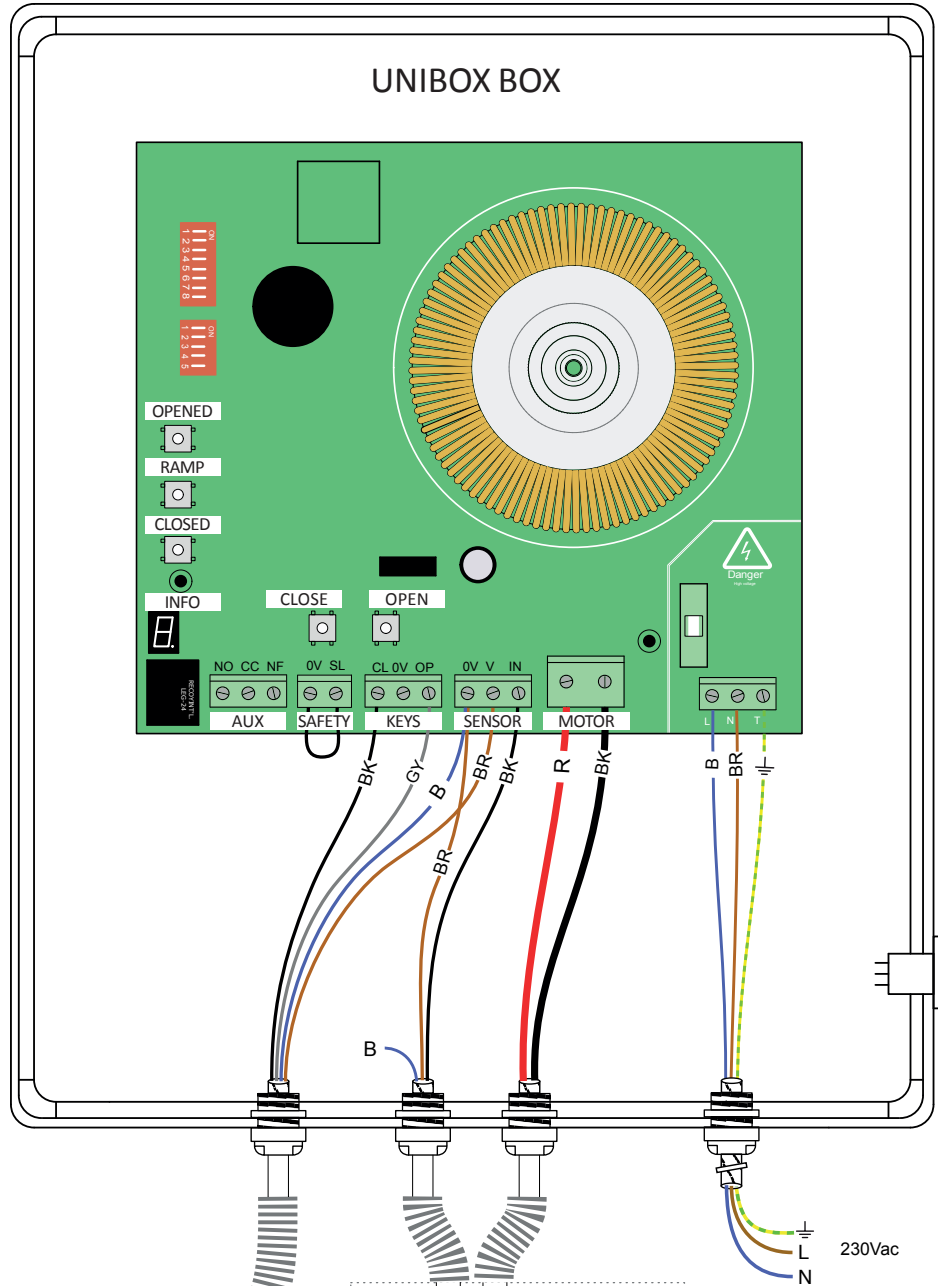
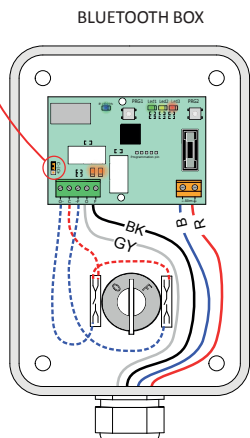

- BKblack..... noir
- GYgrey gris
- Rred rouge
- BRbrown..... marron
- Bblue bleu
- ⏏yellow & green.. jaune & vert

Fig. 32

6.1.2 Bluetooth control box

The Bluetooth control box is a control component for automatic covers.

It is composed of a key-operated switch and a Bluetooth receiver board that can communicate with a terminal running the IOS10 or Android OS5 operating systems on which the "AERO" app is installed.

6.1.2.1 CONTROL BOX DESCRIPTION

Fig. 33

Key operated box with board diagram

- The electric board has a 24 V DC power supply on the "+" and "-" terminals". The board also operates using 12 V direct current, the connections remain the same and the 24 Vdc notes should be read as 12 Vdc.
- The open/close commands are on the O/F terminals. The C terminal corresponds to Common.
- The key-operated switch is connected in parallel (remember to remove the key after each use).

Setting

- In "Continuous press "mode, action on the key-operated switch or the smartphone button is required for the cover to move. Releasing the control will stop the movement.
- In "press" mode, an action on the key-operated switch or the smartphone button will cause the cover to move. To stop, operate the key-operated switch in the other direction or press one of the Stop opening or closure buttons (or press the button again), otherwise the movement will stop at the motor limit switches.
- There are 3 operating modes with 3 viewing LEDs on this receiver:
 - Led 1 (green) default mode: continuous press for closure, single press for opening (compliant with the NF P90-308 standard).
 - Led 2 (orange) mode: single press mode for closure, single press mode for opening. CAUTION: this mode is PROHIBITED in France (not compliant with the standard).
 - Led 3 (red): continuous press for closure and opening (compliant with the standard).
- Switching from one mode to the next on the board: Press the PRG2 button until the 3 LEDs all flash at the same time. Then scroll through the modes by pressing PRG2. The LED flashes on the selected mode. Exit the mode by pressing PRG2 for a long time until the LED stays on without flashing.
- Reset to 0: Press the PRG1 button to turn reinitialise the board.

Box wall mounting

- Fix the control box to the wall using the supplied anchors and screws using the fixing holes provided.
- Position in a location sheltered from the elements, where there is a clear view of the pool, less than 15 m from the pool and without any obstacles between the control box and the smartphone that could interfere with the signal.

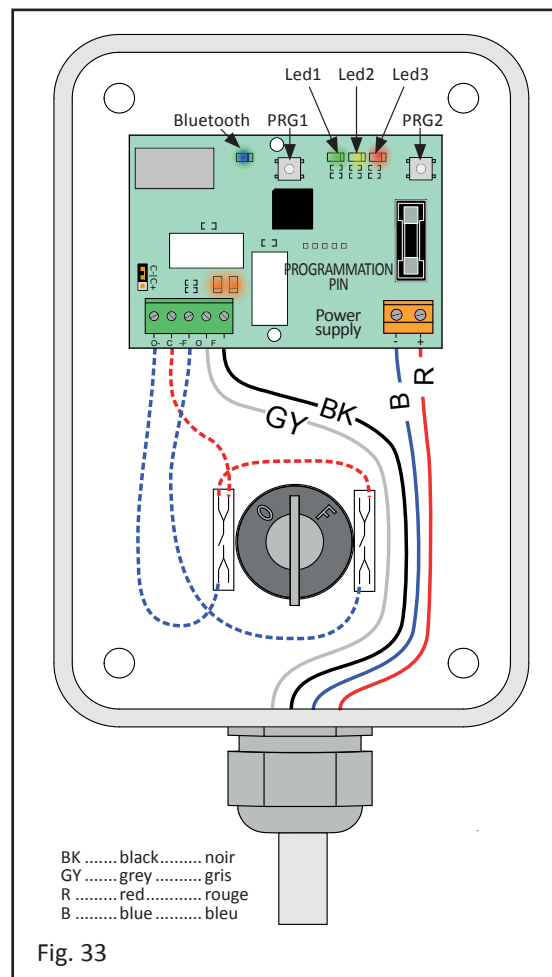

6.1.2.2 INSTALLING AND COMMISSIONING THE AERO APP.

WARNING: Never use the manual control and the remote control (using the app) at the same time as this may put the cover components out of order.

Compatible devices

- Apple® iPhone® smartphones running iOS 10 or later version operating systems.
- Other smartphones running Android® OS 5 versions or later operating systems.
- Any terminal that has the above operating systems.

Installing the AERO app

- Download the "AERO" app from App Store or Google play.
- The links can be obtained directly using the QR codes on the manual cover page and on the control box.

Commissioning the AERO app

- Check that the control box is powered on.
- Make sure that Bluetooth and geolocation are enabled on your smartphone or other terminal.
- Launch the app and follow the instructions.
- To pair the phone with the cover, enter its 4 digit code but only the first time
- (The code is on the manual cover page and on the electronic board).

6.1.2.3 CONNECTING THE CONTROL BOX TO THE COVER

Connect the wires as shown in figure 32.

REMINDER: Invert the wires connected in the box on "OUVERTURE" (OPEN) and "FERMETURE" (CLOSE) if the cover movement does not correspond to the "OUV." (OPEN) and "FERM." (CLOSE) indications on the grey plate of the key-operated switch or the "OUVRIR" (OPEN) and "FERMER" (CLOSE) buttons in the AERO app.

6.1.3 Connection box

Fig. 34

- Plan M27 or M32 cable glands if you use 2 x 10 mm² cable.
- In the connection box, connect the power and sensor wires strictly respecting the colour codes "ROUGE" (RED), "NOIR" (BLACK), "BLANC" (WHITE) "BRUN" (BROWN), and "BLEU" (BLUE) on the box card and the colours of the motor cable wires.
- Use the screw terminals provided for these connections.
- When the cover is installed and the operating tests are complete, and once the limit switch settings are finished, fill the junction box with waterproofing gel to limit the oxidation of the connections which may cause malfunctions.
- The connection box must be 50 cm outside of the volume 0 (see fig. 1) and accessible at any time.

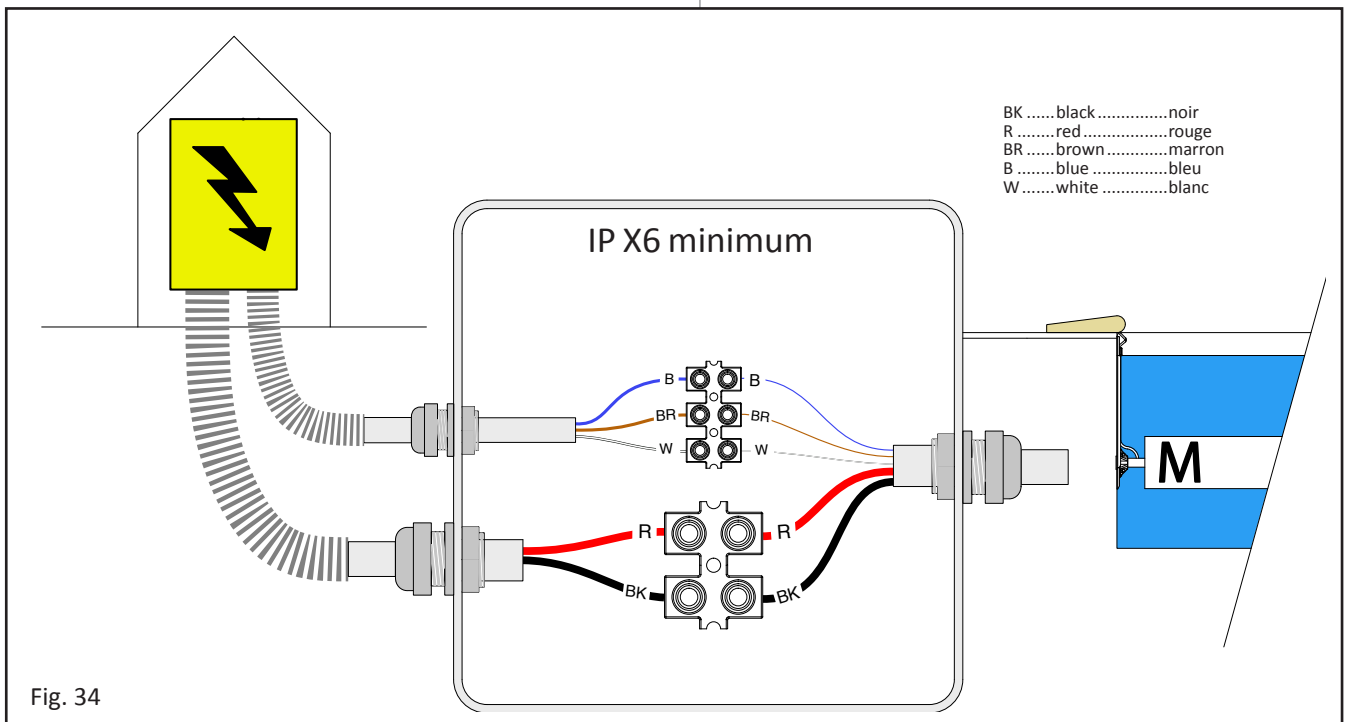

6.2 Adjusting the limit switch stops

Programming mode (should only be used by qualified personnel) This mode is used to program the distance to be run by the pool cover by determining the stop positions (full opening or full closure).

Fig. 35

- 6.2.1 Power on the control box and choose the FORCE mode by positioning the "FORCED" switch to "ON".

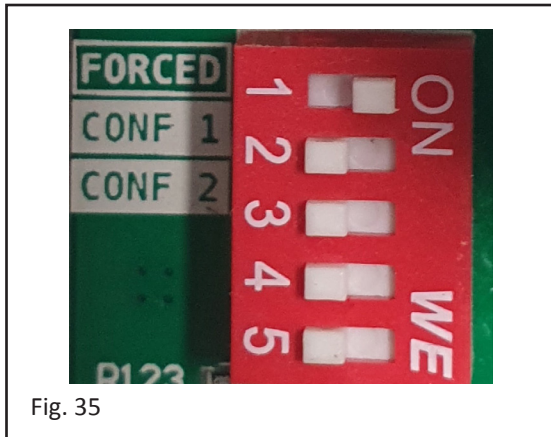

Fig. 35

Fig. 36

- 6.2.2 Use the OPEN and CLOSE buttons or the key-operated contact to check that the motor wiring is correct; if that is not the case, power off the control box and modify the wiring (If the cover moves in the wrong direction and if the switch wiring is correct, invert the motor wires).

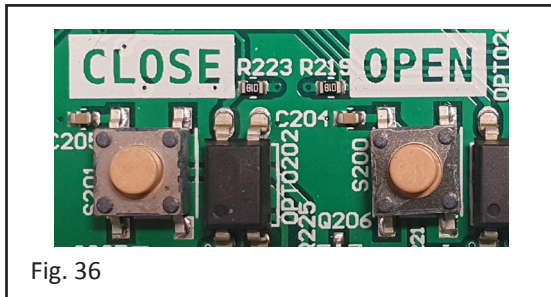

Fig. 36

Fig. 37

- 6.2.3 Once the operation is complete, turn the "FORCED" switch back to "OFF".

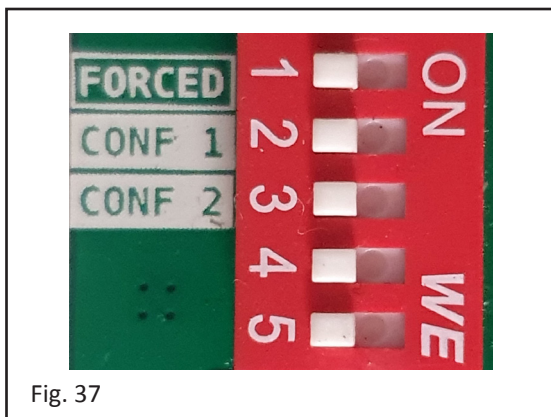

Fig. 37

Fig. 38

- 6.2.4 Press the "OPENED" button, keeping it pressed until the green LED next to it lights. You are in programming mode for the "open" limit switch.
- 6.2.5 Move the cover to the rolled position (fully open).
- 6.2.6 Press the "OPENED" button - The green LED goes out and the position is saved.

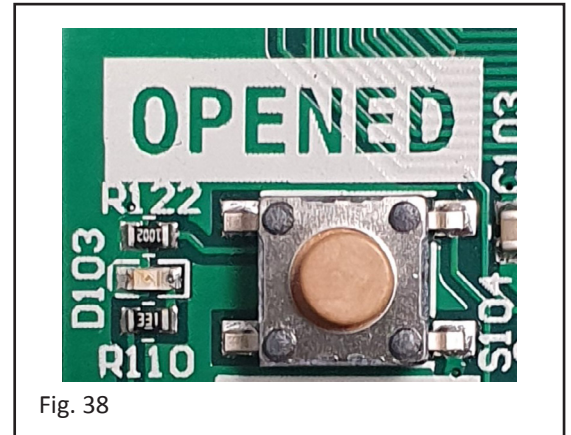

Fig. 38

Fig. 39

- 6.2.7 Press the "CLOSED" button, keeping it pressed until the green LED next to it lights. You are in programming mode for the "closed" limit switch.
- 6.2.8 Move the cover to the unrolled position (fully closed). First make sure there is nothing in the pool and no one is using it.
- 6.2.9 Press the "CLOSED" button - The green LED goes out and the position is saved. The limit switches are now programmed and the board operates in "AUTOMATIC" mode.



Fig. 39

6.3 INFO display

- The INFO display shows the alarms operators use to detect and correct anomalies.
- If there are two active alarms at the same time, the display will scroll through them one after the other.
- Alarms are reset using the motor control system (key-operated contact or remote control). Operating the system twice in the same direction resets the alarm and the motor can be restarted, or for fault 1, switch to FORCE mode ON and run the motor. Switch back to FORCE mode OFF and power the control box off and on again.
- Then reprogram the motor limit switches.

The alarm list is as follows:

0	Steady	Board start up error.
1	Steady	Limit switch programming error.
2	Steady	The motor is not wired.
3	Steady	Defective sensor.
4	Steady	Melted fuse.
5	Steady	Current threshold exceeded (Amperometric control function active).
6	Steady	Alarm on the safety loop active.
7	Steady	Lift prevention alarm triggered; check the straps.
8	Steady	Motor overload.
A	Steady	Acquisition of the current level during closure requested (Amperometric control programming).
B	Steady	Acquisition of the current level during opening requested (Amperometric control programming).
b	Steady	Current acquisition completed without errors: Amperometric control function active.
C	Steady	Error during current acquisition: Amperometric control programming must be carried out again.

For alarm management advice, see section 6.4.

6.4 Troubleshooting table

(only to be carried out by qualified personnel)



WARNING

Before starting any work on the box, and after having cut off the electricity supply upstream of the box, wait 15 seconds for the residual energy in the capacitors to dissipate.



WARNING

If the box malfunctions, or when working using modes other than programming, manual or pairing modes, cut the upstream electricity supply.

DETECTED PROBLEM	ALARM CODE	TROUBLESHOOTING ACTION
The box does not start up when the main switch is turned on.		Check the mains wiring. If the wiring is correct and single phase current is present, if the problem persists, replace the complete box.
When the main switch is turned on, the initialisation sequence stops with an alarm.	0	Power off the board and restart it, if the error persists, replace the complete box.
The board correctly started up after the first start-up, the motor wiring is correct, but impossible to operate the motor.	1	Switch the board to FORCE mode to overwrite possibly saved previous settings; reprogram the limit switches.
During limit switch programming, alarm 2 is triggered.	2	This alarm notifies that the limit switch position has been exceeded; if there are no real reasons for this problem, activate FORCE mode to overwrite the previous values and then completely reprogram the limit switches. Reset the alarm.
The display shows alarm 3 when the motor is running resulting in it stopping; the motor will not start and alarm 3 is displayed.	3	This alarm triggers if there are more than 3 seconds between two sensor pulses. First check the sensor wiring. If there are no wiring problems, switch the board to FORCE mode and check if the motor runs at normal speed when used manually. In that case, the motor internal sensor is broken and it must be replaced by UNICUM: while waiting for the replacement, the cover can be used with precaution in force mode.
The motor will not start and alarm 4 is displayed.	4	One of the fuses has melted; completely power off the board and wait for about fifteen seconds. Remove the various fuses and check them using a tester; replace the defective fuses. Restart the board and check that the motor is in working order.
The motor stops and alarm 5 is displayed.	5	The amperometric control function is active and an obstacle or technical issue has caused the threshold to be exceeded. Reset the alarm and find out why the threshold was exceeded.
The motor stops and alarm 6 is displayed.	6	The safety loop is active and an alarm has caused a motor emergency stop. Check and solve the alarm issue and reset the alarm.
The motor stops and alarm 7 is displayed.	7	The lift prevention system is active and an exceeded current threshold has been detected during the first seconds of cover opening. Check the straps and that there are no obstacles blocking the motor. Reset the alarm.
The motor stops and alarm 8 is displayed.	8	The motor is in overload and stopped to avoid damage. This alarm is triggered when the time between two sensor pulses is more than 3 seconds and a high current value is measured. Reset the alarm and analyse the situation to find out what triggered the alarm.
The motor only runs in one direction.		Disconnect the motor power supply cables and check that the motor can properly move in both directions using a battery. In that case, position the cover at about mid-way. Reconnect the motor to the board and switch to force mode. If the motor only runs in one direction, have the board replaced.
When activating a function using the appropriate dip switch, nothing happens.		To completely reset the optional advanced functions such as the safety loop or opening pulse mode, always reinitialise the board by powering it off and then back on.

7. Accessories and options

7.1 Bend prevention bracket assembly

Fig. 40

- Assemble the bracket bar using the gusset (part 1 and 3). Connection using the screws (part 13 and 9).

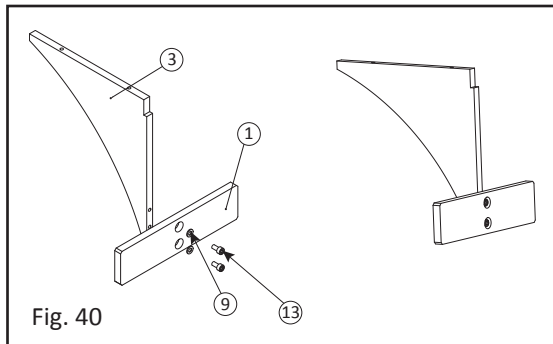

Fig. 41

- Fit the gusset with the beam (part 3 and 4). Use the hardware (part 9 and 13).

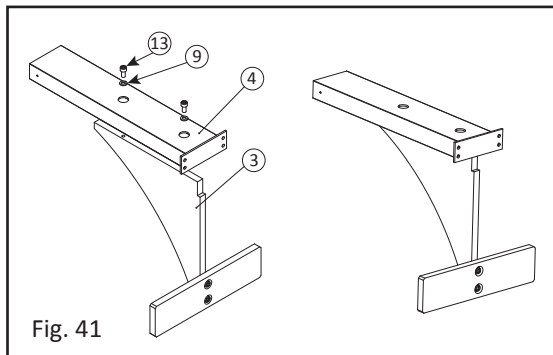

Fig. 42

- Link the gusset to the beam (part 2 and 4). Tighten using the nuts (part 11 and 12).

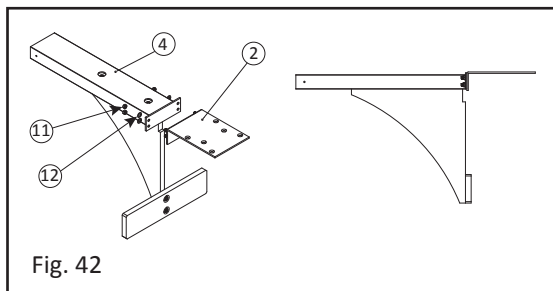

Fig. 43

- Assemble the beam box to the bracket tip (part 6 and 5) assembly using the hardware (part 7, 8, 9 and 10).

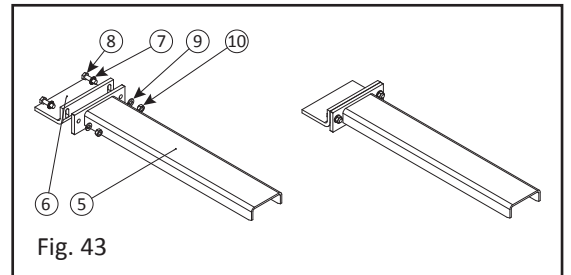
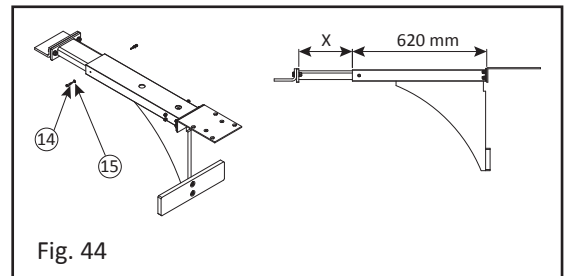

Fig. 44

- Adjust the bracket tip (X measurement) so that it is resting under the beam. Then fix the unit together using self-tapping screws (part 14 and 15).



7.2 Bend prevention bracket installation

Fig. 45

- Provide for a concrete belt dosed at 350 Kg of cement per m³ of concrete of dimension w. 25 cm x h. 40 cm x len. 100 cm of at least 0.10 m³ to stabilise the anti-bending bracket fixing.
- Place the bracket on the levelling course and against the rear wall of the pool.
- Placing the duck boards.
- Drill 10 mm diameter holes of a depth of 70 mm.
- Manually screw the brass plugs onto the TFHC M8 x 60 screws through the stainless steel plate.
- Strike the heads of the screws using a mallet in order to insert them into the concrete belt.
- Tighten and check the solidity of the fixings.
- Install the anti-bending bracket horizontally and properly placing the vertical part of the bracket bar against the pool wall.
- Install blocks under the horizontal plate if there is a liner attachment rail for example, or behind the vertical support to deliberately give an angle to the bracket in order to obtain a horizontal beam once the duckboard walkway is in place.

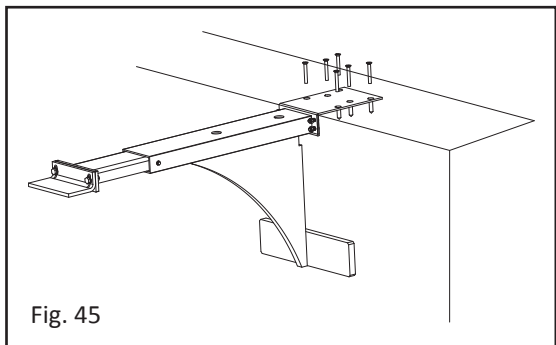

Fig. 45

- Evenly distribute the consoles according to the width.

7.3 High water level duck-board anti-bending bracket

Fig. 46

The height between the partition wall and the levelling course is 155 mm maximum.

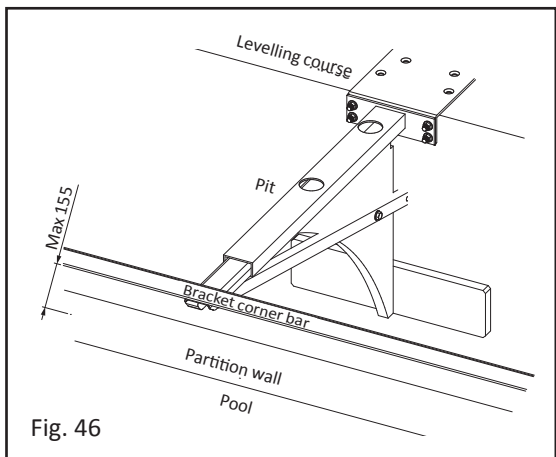

Fig. 46

Fig. 47

Fix the bar to the gusset using the 2 TH 10 x 30 screws and M10 washers.

Fix the beam to the gusset using the TH 10 x 35 screws and M10 washers.

Fix the console bracket to the beam using the 4 M8 nuts and washers.

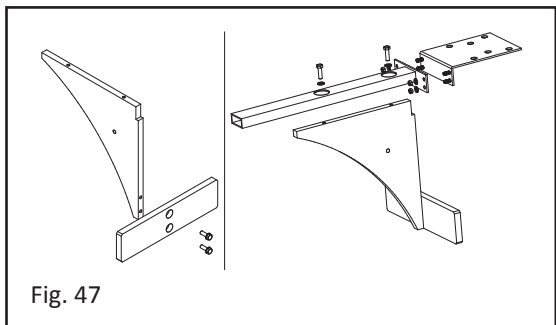

Fig. 47

Fig. 48

Fix the console tip, the slat guide and the lateral guide using the M8 threaded rod and the 2 M8 nuts.

Fix the lateral guide to the gusset using the TH 8 x 55 screw, the two M8 washers and the M8 lock nut. Knot the counterbalance bungee cords to the threaded rod and use the four end nuts to block them.

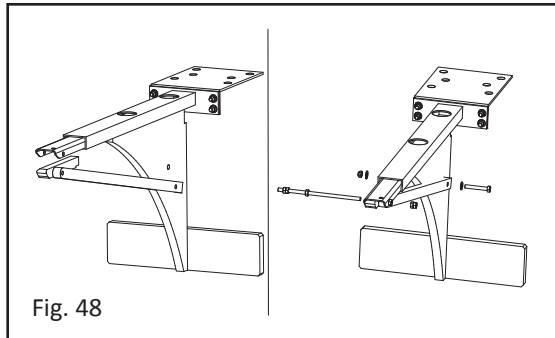

Fig. 48

Fig. 49

Saw the back part of the lateral guide which may protrude on size 800 duck boards.

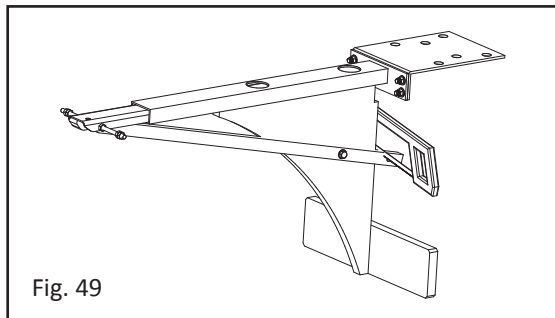

Fig. 49

Fig. 50

Position the two end consoles at 250 mm from the pool edge.

End console: If there are curved corners (max 150 mm). Adjust and cut the wall support plate on the curved side if necessary.

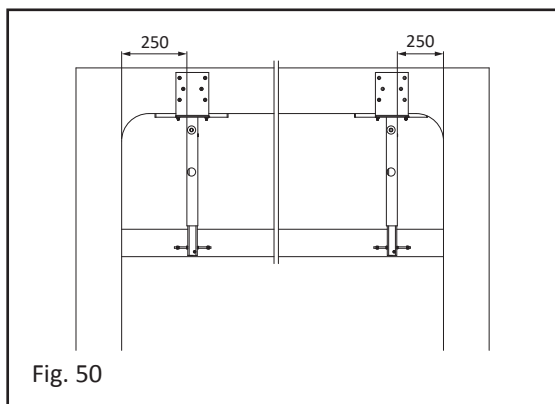

Fig. 50

Fig. 51

Adjust and fix the corner bar with the levelling course fixings at each end, link using CHC M6 x 16 screws 2 washers and lock nut.

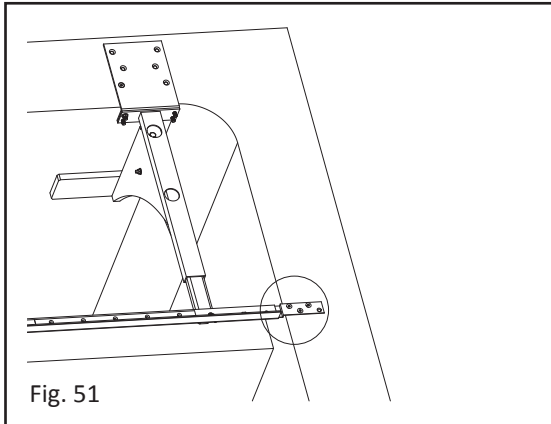

Fig. 52

Place the other consoles keeping a constant spacing of less than 1 metre so that the fixing holes (console/corner bar) coincide.

Fix the levelling course consoles using TFHC M8 screws and anchors.

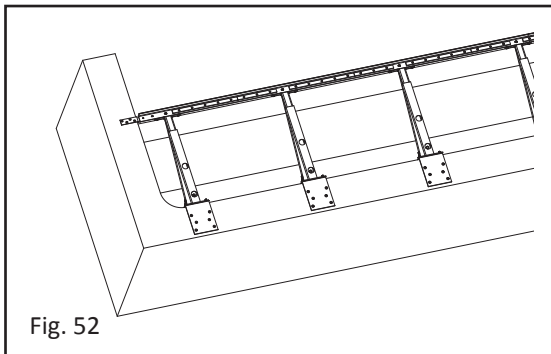

Fig. 53

Fix the consoles and the corner bar (TRHC M6 x 16 screws, 2 washers and a lock nut).

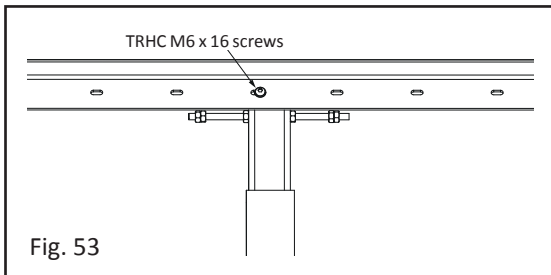

Fig. 54

Fix the blocking bars by screwing them in at each end (TFHC M6 x 20 screws and lock nut). If necessary, cut them to length.

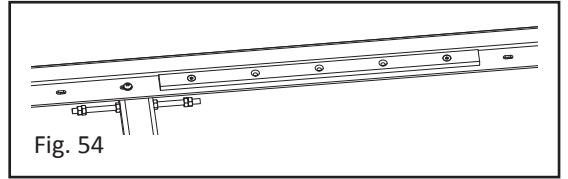
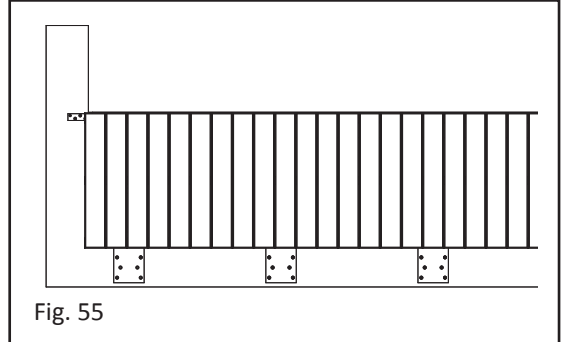

Fig. 55

Place the duckboards to complete the installation.



7.4 Fixture on the edges

7.4.1 Fixing the flanges to the edge

Fig. 56

- Assemble the stainless steel fixing plate with the cover using the M10 nuts and washers.
- Use the stainless steel supports as a template to mark the position of the 4 fixing holes on each side of the pool (they must be carried out as close as possible to the pool depending on the structure's reinforcement elements).
- Drill $\varnothing 12$ mm holes of a depth of 70 mm.
- Manually screw the brass plugs onto the TFHC M10 x 60 screws through the stainless steel plate.
- Strike the TFHC M10 x 60 screw heads using a mallet in order to insert them into the concrete belt.
- Tighten and check the solidity of the fixings.
- If necessary use the supplied wedges to ensure that the edge plates are horizontal.

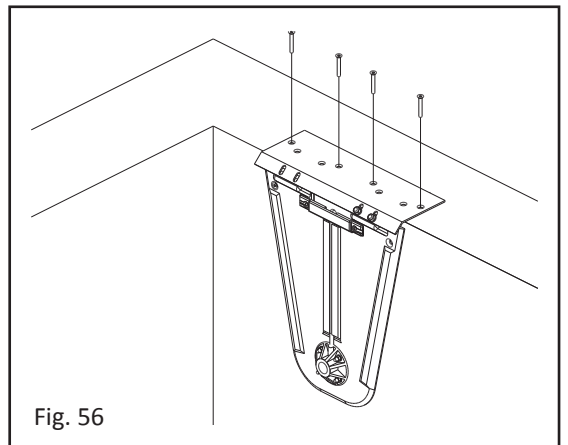

7.4.2 Fixing the sliders to the edge

Fig. 57

- Assemble the stainless steel fixing plate to the slider using the stainless steel studs on the top part of the slider.
- Use the stainless steel supports as a template to mark the position of the 2 fixing holes on each side of the pool.
- Drill 10 mm diameter holes at a minimum depth of 60 mm.
- Manually screw the brass plugs onto the TFHC M8 x 55 screws through the stainless steel plate.
- Strike the heads of the TFHC M8 x 55 screws using a mallet in order to insert them into the concrete belt.
- Tighten and check the solidity of the fixings.
- The beam box is fitted to the slider using M8 nuts.

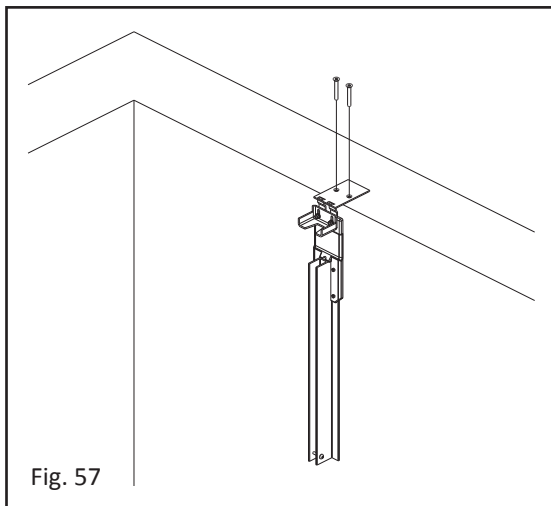

7.5 Chemical seals with insert

- For M8 screws, drill diameter 14 mm to a depth of 65 mm,
- For M10 screws, drill diameter 20 mm to a depth of 70 mm,
- Blow the drill holes to clean them,
- Inject a dose of chemical sealer and place the insert,
- Respect the drying time indicated on the cartridge.

7.6 Positioning the fastenings for beams

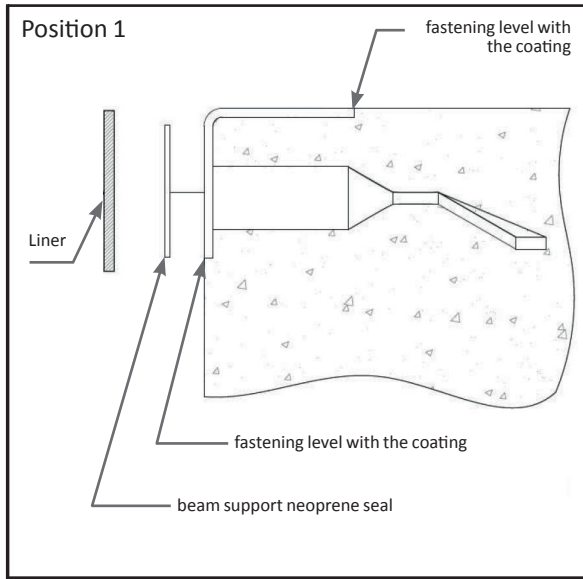

80 mm beam

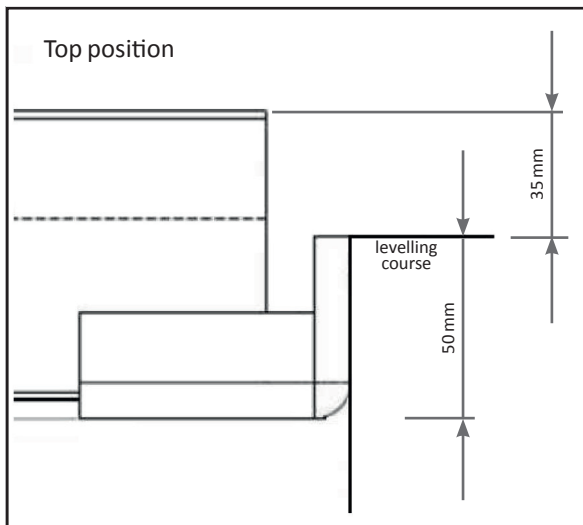

120 mm beam

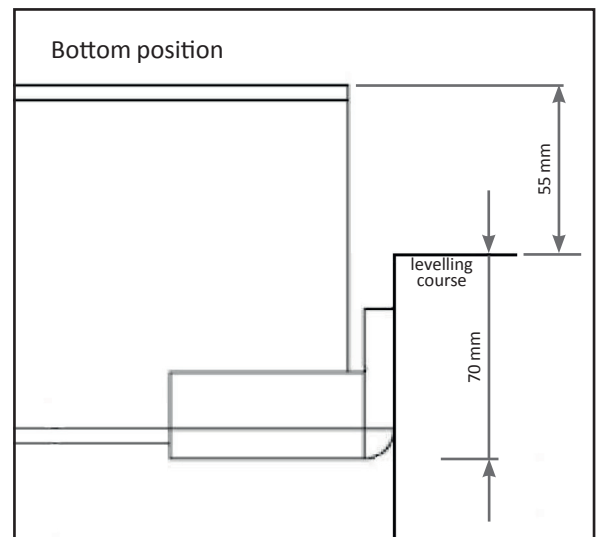
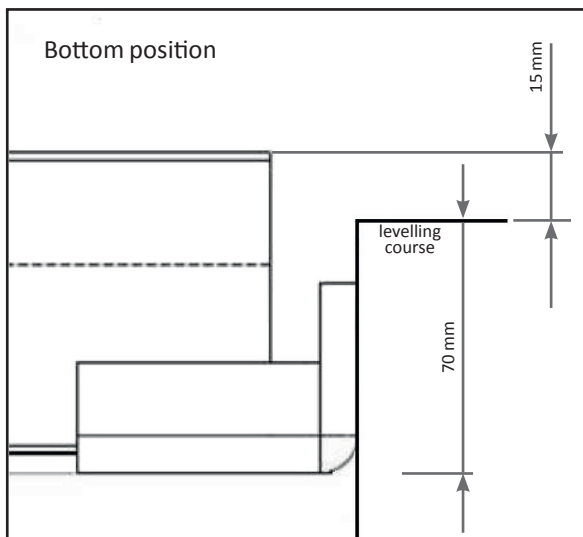
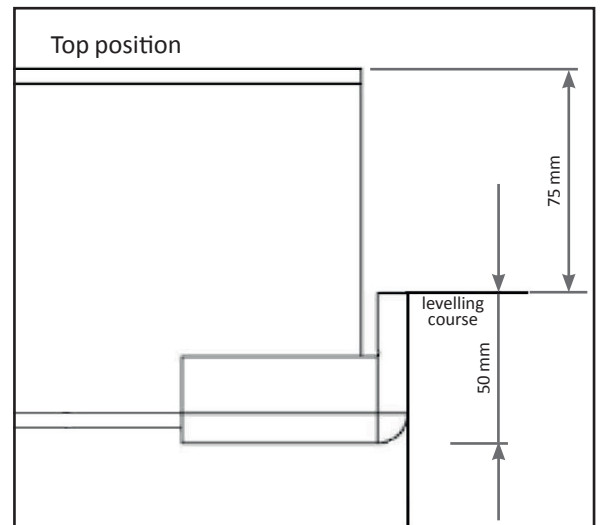

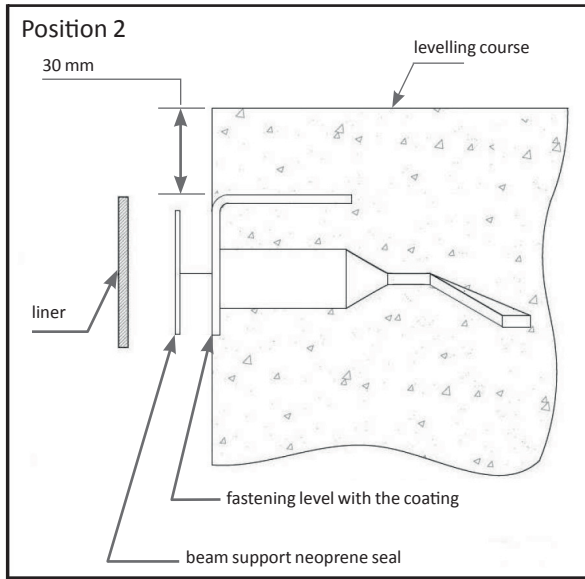

80 mm beam

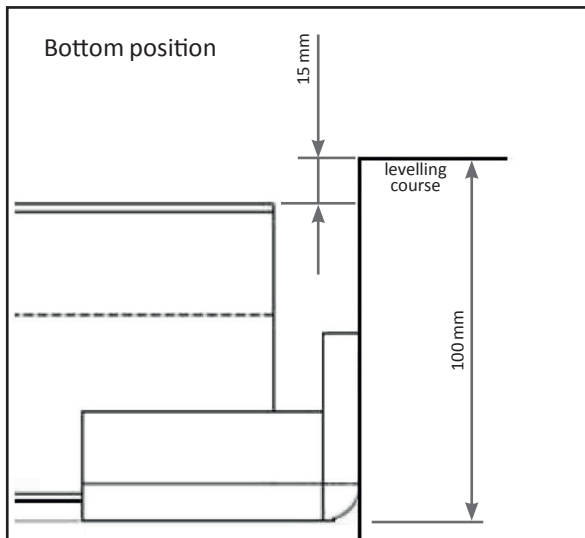
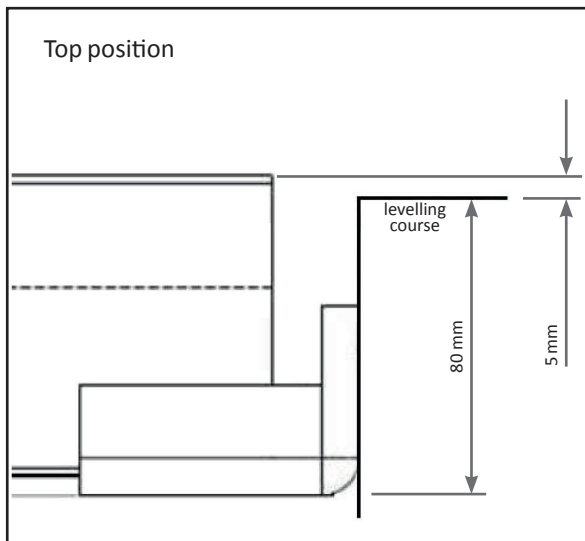

120 mm beam

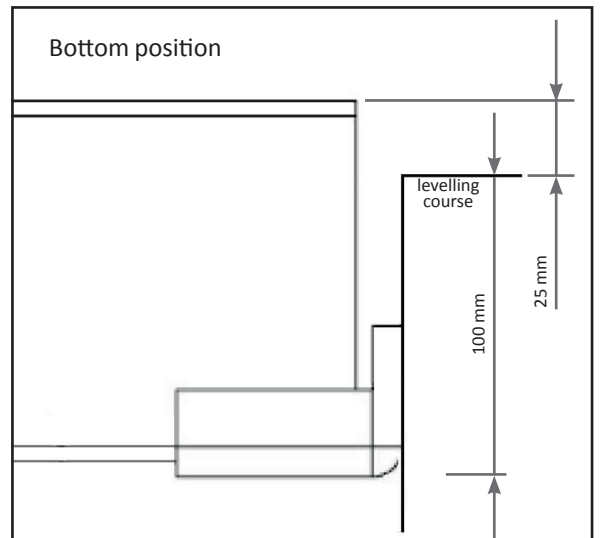
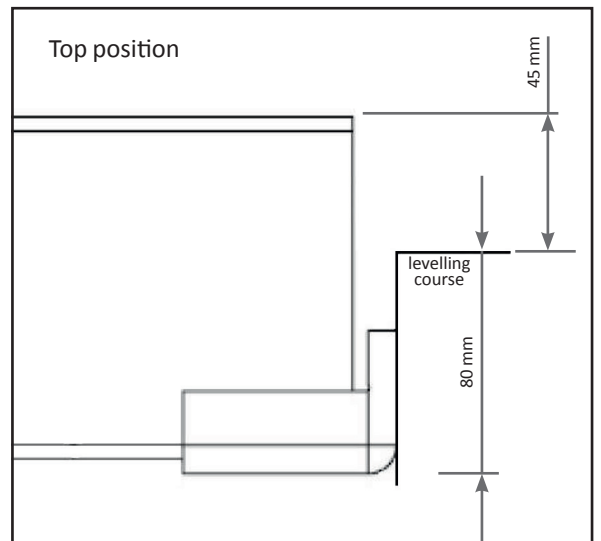

8. Test instructions in the event of a malfunction

Abrible makes its malfunction test guides available to you in video format.

Go to:

www.nextpool.com/

Pro area/

"Abrible" tab /

"Advice and Assistance" section

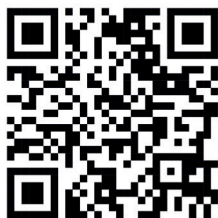

The following list has been drawn up in order to help diagnose and correct malfunctions that may occur during installation. This guide is exclusively for the professional authorised to install the cover in order to maintain the validity of the guarantee. If, after having followed these instructions, the cause of the malfunction has not been found, the professional must contact the cover retailer or manufacturer.

Read completely before carrying out the operations. Refer to figures 25 and 27.

Turn the switch on the box to Off or "0" before each connection, disconnection operation.

Check the condition and the correct tightening of the electric connections.

8.1 Box checks

- 8.1.1 Check that the fuse and the thermal circuit breaker are in working order.
- 8.1.2 Check the power relay operation.
- 8.1.3 Disconnect the 2 wires connecting the box to the roller motor from the "+" and "-" terminals.
- 8.1.4 Turn the switch on the electric box to On or "1".
- 8.1.5 Check that the command and power diodes are on when the box is powered on.
- 8.1.6 Step by step, measure the presence of the indicated.
- 8.1.7 Voltage on the circuit at the following terminals:
- 8.1.8 Box power supply test: 230 V AC (Alternating) on terminals "L" and "N" of the control box to which the 230 V is connected.
- 8.1.9 Transformer test: 20-24 V AC between the red and blue plugs, and 10-12 V AC between the White and Blue plugs exiting the transformer.
- 8.1.10 Motor terminal tests: 24 V DC between the "+" and "-" terminals of the motor when activating an open or a close.
- 8.1.11 Terminal tests: If there is a malfunction check that the cable terminals are correctly connected to the board.

8.1.12 If a voltage is not present or of a different value, check again making sure that the multimeter tips are in contact with the terminals and that your multimeter is calibrated and on the correct measurement position. A voltage that is absent or different from the indicated voltage indicates that the tested component is defective. Replace it or request its return to AS POOL for analysis.

8.1.13 If the box is correctly supplied, the fuses in good condition, and if the cover does not move, the box is no longer operational (this can be due to a power surge from an incorrect connection, a thunder storm or a defective component. The box must be returned to AS POOL for analysis). If the cover moves more than one metre: the box is working correctly.

8.2 Check your power supply cable between the box and the roller motor

- 8.2.1 Reconnect the roller power cable to the box and disconnect it from the junction box.
- 8.2.2 Step by step, check for the presence of the indicated voltage on the following terminals:
- 8.2.3 Connecting cable test: 24 V DC in the box at the terminals marked "+" and "-" where the connecting cable is connected. Then 24 V DC on the terminals for the 2 wires arriving at the junction box. If the voltage is below 22 V, this voltage will not be sufficient for the correct operation of the motor.
- 8.2.4 Check that the cable sections correspond to what is indicated on fig.1, the quality of the connections (make sure of the continuity of the connections in the junction box and the box), the absence of humidity or even water in the connection box (Reminder: the connection box must always be filled with gel).
- 8.2.5 If voltage is not present or the value is different, it means that your cable is defective, cut, damaged or has the wrong resistance, or is located too near to a cable with a different voltage that disrupts its operation. Replace the cable. Make a temporary connection using another cable directly between the electric box and the motor to carry out new tests.

8.3 Direct check of the motor

- 8.3.1 If the cover does not move, check the motor sensor operation (return data) by checking:
- that the motor cable is in good condition.
 - the correct positioning of the stainless steel blocking ring against the roller tube so that the flanges are correctly placed against the pool walls.
- 8.3.2 If these elements are correct, the motor sensor is out of order (this can be due to a power surge related to a faulty connection, a storm, or a defective component. The motor must be returned to AS POOL for analysis).

8.4 Checking the Bluetooth control box electronic board

- 8.4.1 Power on the control box and check that the board is powered on.
- Check that "led1" indicator on the electronic board is on.
- Measure 24 V dc (or 12 V dc) on the "+" and "-" terminals of the electronic board.
- 8.4.2 Check that the Bluetooth LED is flashing blue (if the led flashes twice, it means the electronic board is paired with a terminal).
- Check that the orange LED light when opening and closing using the mobile app.
- Powering off the control box cuts the Bluetooth signal and allows the electronic board to be reinitialised at all times.
- Check the board electric connections using the wiring diagram.
- Check the following terminal blocks:
- "O C F": key-operated switch pre-wiring, "C" for Common, "O" for Opening and "F" for closure.
 - "O F - +": wiring to the electric box terminals, "O" for Open and "C" for closure, "-" for the 0 V and "+" for the 24 V (or 12 V dc).

9. Checks

Check the following points relating to the NF P 90-308 standard and check that the cover operates correctly:

- When turning the key switch for the cover, the entire pool is visible and check that there are no bathers in the pool when closing the cover. The unrolling operation stops when the key is released. The key can be removed from the control box.
- The cover rolls and unrolls correctly.
- The safety mechanisms are easily handled for the recommended water levels and are sufficient (number and position). Check that they are locked on completion of the installation.
- The gaps along the length between the cover

slats and the pool wall are less than 7 cm and the cover does not rub "abnormally" against the wall.

- The cover protection (duckboards) is stable and resists intrusion and lifting using a force of less than 50 N (5 kg).
- The space between the bottom of the beam supporting the duckboards of a submerged cover and the partition wall is 150 mm maximum.
- The gap between the bottom of the partition wall and the bottom of the pool is less than 100 mm.
- The slat cover supply voltage is less than 30 VDC.
- The limit switches (if they exist) are in working order.
- The site is cleaned after installation of the cover and the packaging and waste is removed.
- The user manual has been given to the end user.
- The cover's guarantee form is filled in and signed.
- "Waste Electric and Electronic Equipment" (WEEE) is the subject of specific collection. It should not be disposed of with your unsorted household waste.



10. Receipt of the slatted cover by the end customer

- The installer explains the operation of the ABRIBLUE cover to the end user and informs him/her of the safety, usage, upkeep and winterisation advice.
- They give them the cover instructions.
- They demonstrate the use of the cover and explain its functional limits.

The installer and end user fill in and sign the guarantee form attesting to the compliance of the installation, the reception of the documents for the cover and the information given to the end user featured in the cover safety instructions.

11. Appendix: troubleshooting assistance tool

Information



1. The screen permanently displays the number of counted rotations (when opening) or counted down rotations (when closing). It also indicates the consumed intensity and the rotation speed. The value of the counter in the closed position (around 0) is less than the value of the counter in the open position (between 7000 and 8000).

2. A timer delays motor start-up for half a second when the key is turned.

Troubleshooting assistance:

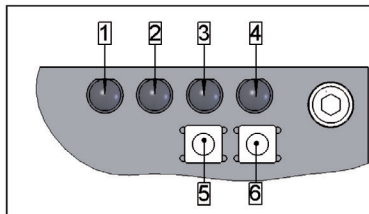

1. Command voltage present.
2. Power voltage present.
3. Motor indicator: anti-clockwise rotation.
4. Motor indicator: clockwise rotation.
5. Motor forcing button in anti-clockwise direction.
6. Motor forcing button in clockwise direction.

Contact info:

When the pool is closed the info LED is on, the NO contact is closed, the NC contact is open. These contacts are free of electric potential. Cut-off power: resistive load: 0.3A at 125V, 1A at 30 VDC, inductive load: 0.2A at 125Vac, 0.5A at 30VDC, max. voltage: 250Vac, 220VDC.

ERROR MESSAGES

Sensor error



The rev counter signal remains in the same status. The system jams. Only a new reset can relaunch the system. Check the sensor connection.

Cycle error



The motor has an uninterrupted power supply for 5 minutes. The action is suspended and the motor is stopped for 20 seconds. No actions can be carried out during this time.

Overload



The electronic circuit breaker has stopped the motor: operating intensity greater than 10A.



On the same open or closure cycle, if this error occurs three times, this display will flash showing the screen opposite. To reset the system, press the control box On/Off switch.

Product: IMM'Ax
Company: AS POOL
Address: ZAC de la Rouvelière
F-72700 SPAY- LE MANS
Phone: +33 (0)811 901 331
Fax: +33 (0)243 479 850
contact@abriblue.com
www.abriblue.com

SLATTED COVERS

Safety instructions and user guide for the automatic pool cover

Please read carefully and keep available for later use
02/2023 Version

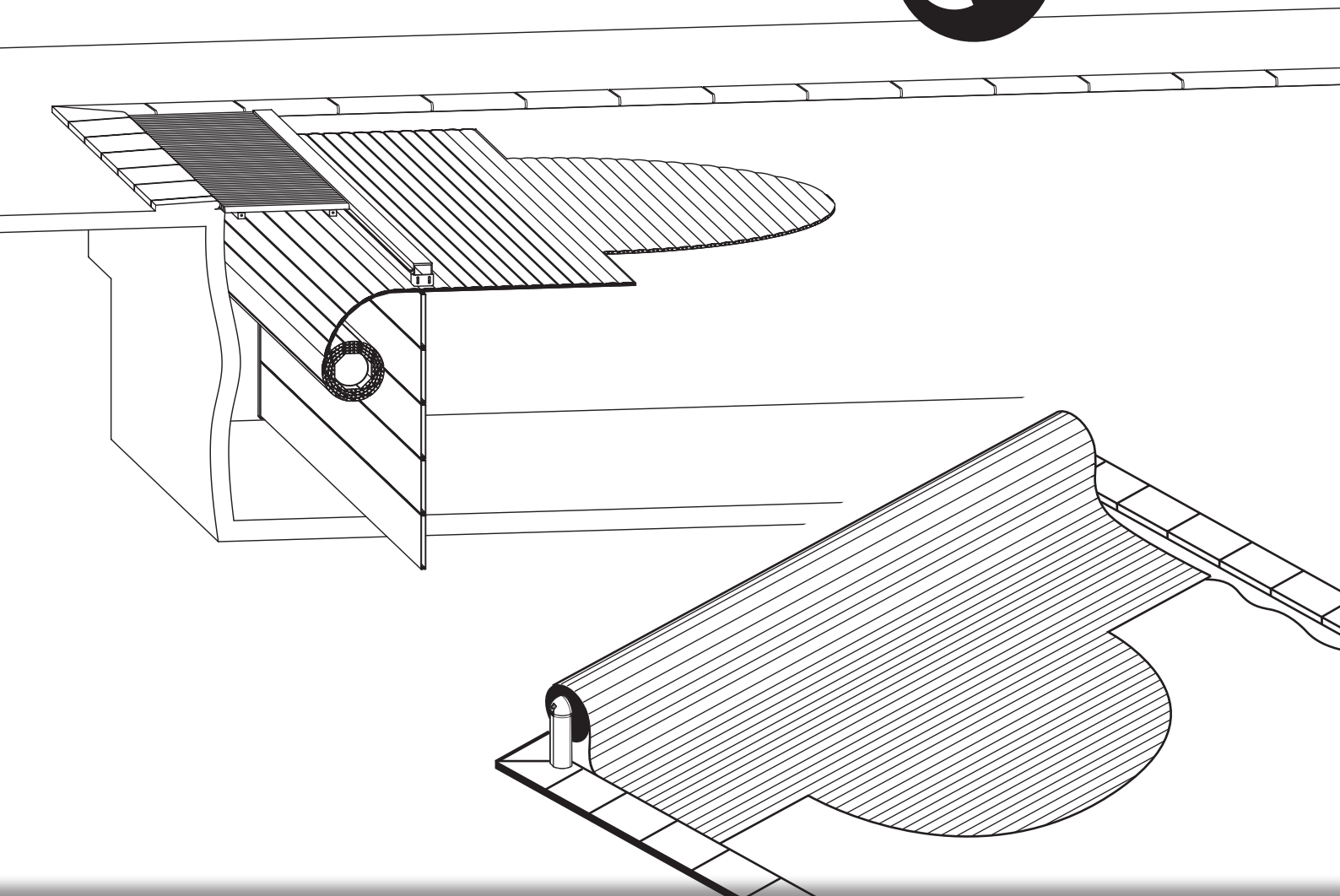
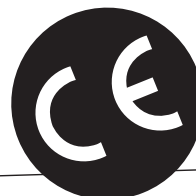

CONTENTS

- 1. Safety Advice..... 2
- 2. Slatted cover presentation..... 3
- 3. Advice for use..... 5
- 4. Upkeep advice 6
- 5. Maintenance advice..... 7
- 6. Winterisation advice..... 8
- 7. Guarantee..... 8

Compliance certificates



1. Safety Advice

WARNING:
The pool can constitute a serious danger to your children. Drowning happens very quickly. Children close to a pool require constant monitoring and active supervision even if they can swim.
The physical presence of a responsible adult is indispensable when the pool is open.

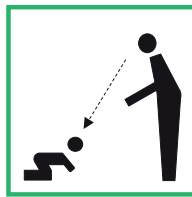
Learn the actions that save lives.

Memorise the emergency service phone numbers and display them near the pool:

The phone numbers to have on hand in an emergency

European emergency call number: 112
 Fire brigade: 18 (in France)
 Ambulance: 15 (in France)
 Poison Centre (the number for your region)

- This cover is not a substitute for common sense or personal liability. Its aim is not to be a substitute for the vigilance of parents and/or responsible adults, which remains the essential factor in the protection of young children.
- Be aware that safety is only assured with a closed, locked cover which is correctly installed in compliance with the manufacturer's instructions.

- The cover must be systematically unrolled and locked during absences, however short, from the home.
- Check that there are no bathers or foreign bodies in the pool before activating the cover.
- Keep the tools needed to activate the covers out of the reach of children.
- Only a responsible adult should undertake to manoeuvre the Cover.
- It is prohibited to climb onto, walk on or jump on a safety cover.
- Take all necessary measures to prevent access to the pool by young children, until the cover is repaired, or when a malfunction prevents the closure of the cover to secure the pool, or if the pool equipment is temporarily unavailable.
- Comply with the water levels defined by the manufacturer.

2. Slatted cover presentation

2.1 Automatic pool safety cover description

The automatic safety cover is composed of a floating slat cover that unrolls and rolls around a motorised roller shaft (above ground or immersed) that covers the pool surface to prevent or authorise bathing. Closure and opening takes about 3 minutes.

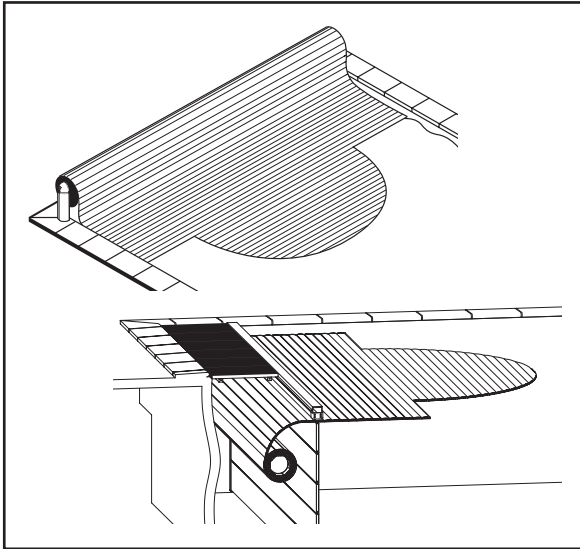

They are manufactured in compliance with the NFP90-308 standard that imposes production requirements to protect children from drowning (especially protection from electric, entrapment and ducking risks).

The unrolling and rolling shaft rotation uses a 12V or 24V DC drive gear motor powered by a 230V AC/24V DC (or 230V AC / 12V DC) electric box located in the technical space. Rotation speed is about 5 rpm. The sound level generated by the automatic safety cover when running is > 65 dB.

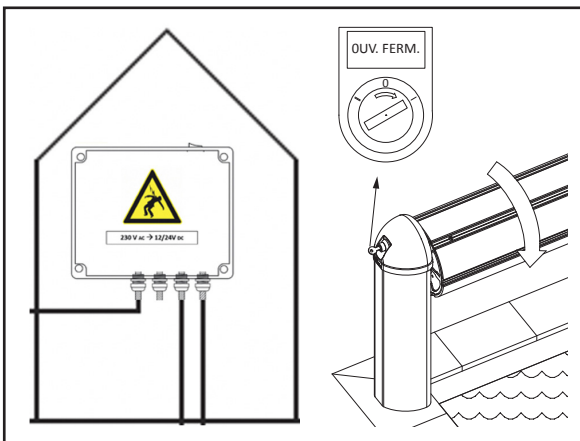

The cover is controlled using a control that is locked using a key or an access code placed in the immediate pool vicinity.

Casing can cover the roller for a more aesthetic look or to isolate the bathing area.

"Safety" systems are located at the ends of the slatted cover to fix it to the pool when it is fully unrolled over the pool to prevent access to the water.

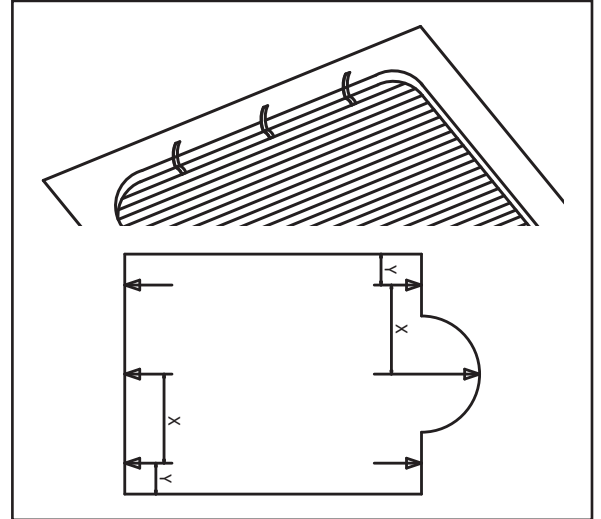

2.2 Normal automatic pool cover use and contra-indications

2.2.1 Normal automatic pool cover use

See table on page 4

2.2.2 Automatic pool cover use contra-indications

Do not attempt to roll in the cover without having unlocked the fastening systems.









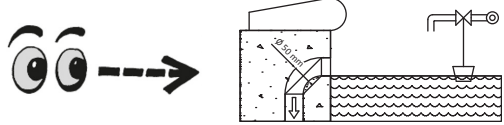

Do not roll in the cover if there are objects or people on the cover.

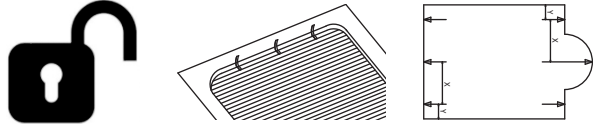
Do not activate cover closure if there are floating objects or people in the pool.

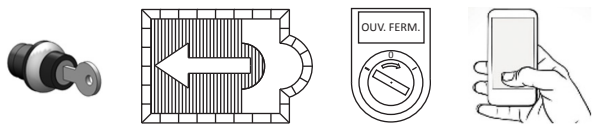
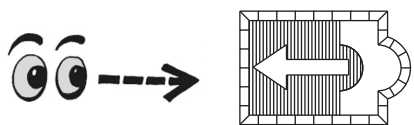
Do not touch the roller during rotation.

Do not stop the cover in an intermediate position during the rolling or unrolling phase

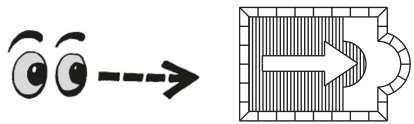
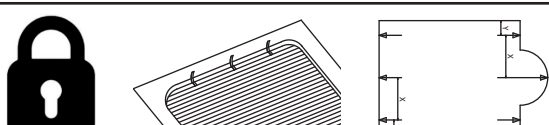
Do not leave the key on the control station. Do not disclose the phone locking key or eliminate the presence of the code.

1	Check that the pool water height is compliant with its operating level.	
2	Remove all floating objects from the pool or objects on the cover.	
3	ROLLING IN THE COVER: Before uncovering the pool, unlock the pool fastening systems.	
4	Use the control key or enter the remote control code.	
5	Insert the key into the barrel and activate the "Open" direction or press the "Open" key until the movement is complete.	
6	Keep a permanent view over the cover and the pool while it is moving. Make sure to keep people away from the roller.	
7	Keep the control key or the remote control out of the reach of children.	
8	UNROLLING THE COVER: Before covering the pool, make sure there are no bathers in the pool.	
9	Use the control key or enter the remote control code.	
10	Insert the key into the barrel and activate the "Close" direction or press the "Close" key until the movement is complete.	
11	Keep a permanent view over the cover and the pool while it is moving. Make sure to keep people away from the roller.	
12	After covering the pool, fasten all the cover safety systems on the pool.	
13	Keep the control key or the remote control out of the reach of children.	

3. Advice for use

- Always check that the pool water level remains constant and in compliance with the manufacturer's recommendations (-12 cm as a standard) before using the cover in order to avoid jamming the slats in the trench (against the beam or the partition wall), or to prevent them from rubbing against the pool copings, or to avoid the slats being warped by excess or insufficient water levels. Make sure that the overflow and the water level regulator are operational so that the skimmers do not suck in air if the water level is too low.
- Remove all floating objects that could hinder the correct operation of the ABRIBLUE cover during its closure, and lock the access to the pool using the blocking straps.
- Do not forget to unlock the safety mechanisms before opening the pool cover as failure to do so may damage the pool cover.
- Always keep the pool in full view during the opening and closing operations. It may be necessary to accompany the cover manually during rolling or unrolling operations in order to position it correctly if there is a strong side wind, a free form pool, or a pool with a specific configuration.
- It is imperative not to halt the cover in an intermediate position, this can cause the risk of jamming a bather's body at the level of the cover casing, if a bather uses the pool. The person carrying out the action must make sure there are no bathers in the pool before starting.
- Check that the hose or power supply cable of the pool cleaner does not get tangled in the cover; this could jam the operation of the roller and damage the PVC slats.
- Check that unrolling and rolling runs correctly over the first few metres (the slats roll effortlessly, there is no jamming on the shaft with the top "bulging" towards the outside of the roll), and if necessary, stop the action immediately in order to intervene on the cause of the malfunction.
- The rotational speed of the shaft is not constant due to the rolling/unrolling of each new layer of slats which unbalances the roller. Adapt the wheel's rotational speed on the manual model in order to avoid the harder spots by handling the wheel with both hands.
- It is imperative during rolling or unrolling operations, not to release the control until the limit switches have been reached (especially on the BANCS) in order to correctly position the slats on the roller when rolling in is complete, or on the water when unrolling is complete.
- On the model without limit switches, make sure not to roll-in the slats too much in order to prevent them from falling to the rear and breaking.
- Do not operate the cover more than 15 consecutive minutes.
- It is prohibited to manoeuvre the cover if there is a load on the duckboard walkway of a submerged cover, this might cause the cover to scrape the beam.
- Prohibit an overload on the duckboard walkway for a submerged cover due to the physical limits of the beam and the fixtures. The duckboard walkway is supported by the pool edge and the beam, and is designed to support a maximum load of 400 kg over its complete length (duckboard included) and 150 kg per linear metre.
- Do not walk or jump on the covering of the BANC roller in order to avoid deforming it.
- It is essential, for safety reasons, to remove the key from the control box or the manual wheel, or to close the Aero application once the opening or closure actions are complete.
- Programme the filtering system to start as soon as the "solar" slats are in sunlight. During very sunny periods with the cover closed, the water temperature can reach 30° or more and can damage the slats.
- It is strongly recommended not to empty the pool without the authorisation of your installer.
- If the cover is fitted with a WING System[®], take care not to operate the cover without having folded the WING System[®] onto the cover. Operating the cover with the WING System[®] deployed can cause major damage to the cover and the pool.
- If the cover is fitted with a SURF System (mobile roller), two people are required to move the roller. Make sure the roller is correctly positioned on the pool before any automatic action of the slats.
- In the case of an emergency operation, a person walking on the cover will have his/her feet under the water.
- Limit operating the slatted cover when the temperature is below 5°C and do not handle the cover below 0°C when it is locked in ice. Avoid all impacts and mechanical contacts on the slats when the temperature is below 0 °C.
- When the cover is installed on a sheltered pool, make sure that the air temperature is no higher than 40 °C. Make sure that the surrounding air is ventilated in order to avoid all distortions and deteriorations of the parts (PVC slats, bench panels, duckboards, etc.).
- Regularly remove any debris from the slat cover. They will thus prevent rolling it in with an accumulation of leaves or debris that could cause brownish stains to appear on the slats. This natural phenomenon is not covered by our guarantee.

4. Upkeep advice

The maintenance of the ABRIBLUE automatic cover is at the expense and under the responsibility of the user.

- The use of an automatic cover maintains the quality of the water and reduces the amounts of treatment products needed.
- Maintain a good water balance in order to avoid damaging your automatic cover.

Water characteristics	Minimum recommended value	Maximum recommended value
pH	7.2	7.6
Chlorine	0.7 ppm	1.2 ppm
Bromine	1.5 ppm	2.5 ppm
TAC	80 ppm	120 ppm
TH	100 ppm	300 ppm
Stabiliser	10 ppm	40 ppm
Temperature	1°C	30°C

- Prolonged or repeated overdoses of products are damaging to the PVC slats. An acid pH below 7 can corrode metal parts. A lack of treatment causes the proliferation of algae and favours the putrefaction process which can cause the irreparable appearance of brown stains on the PVC slats.
- Check the operation of the electrolyser when the pool is closed for long periods. This type of device cannot be fitted with a production stop and can cause irremediable damage to submerged mechanisms (corrosion) in the event of a high concentration of stagnant chlorinated products in contact with the PVC slats. To correct this situation, occasionally air the pool water by opening the cover taking care to guard the access to the pool while it is open.
- During a superchlorination operation, roll up the cover, start the filtering system and prevent access to the pool by children under 5 years old.
- Clean your cover at least twice a year using a high pressure cleaner or a sponge using a descaling product and/or a degreasing product (water line gel type). Do not use a solvent or abrasive product as these may damage the PVC slats. Do not spray water onto the shaft as this might damage the motor.
- During the summer period, clean the slat storage pit once per month using a manual vacuum brush. Regularly remove any debris from the cover.
- Check the correct operation of the water level regulation (overflow not clogged, automatic filling correctly set).
- Make sure that the area where the cover motor is located is fitted with a drain preventing the motor from being submerged at all times (in case of flooding).
- Check that the slats are not subjected to temperature differences greater than 15° between the outside air and the water in order to prevent them from warping (case of a highly heated pool in a cold environment: mountain for example).
- When using a cover installation under a shelter, make sure the shelter is aired and limit its temperature to 40 °C maximum and prevent the slats and bench panels from overheating.
- Protect wood elements such as duckboards and bench panels. Wood, whatever its origins, is subjected to the aggression of the environment on a daily basis: walking, bad weather, dampness or dry weather. It therefore needs a minimum of maintenance. Prefer a wood saturator. For it to be efficient we recommend that you apply it using a brush until saturation in order to stabilise it and avoid tannins from being rejected. The coats must be applied when the previous coat is still damp, without any drying time between them (2 or 3 coats depending on the porosity). Avoid wax or silicone based products, they are very quickly decomposed by UVs and washed away in bad weather. Depending on climatic conditions, exotic woods become silvery grey over time. Avoid varnishes, they form unstable films which are subject to flaking. We recommend the products Durieu DESKS OLJE D1 (mentioned in the "Techniques PISCINES" review) for the maintenance of exotic woods. If you have tannin stains on your pool copings or protective cover, we recommend the application of concentrated bleach using a brush followed by copious rinsing.
- Do not cover the opaque slats with a hermetic tarpaulin, this would risk creating a major heating effect (greenhouse effect) which could cause the slats to warp permanently.
- Check the good condition, tightness and correct fixture of the safety loops.
- Check that the straps linking the slats to the shaft are always tightly in place and evenly distributed.
- Check the ends of the slats, check that they are aligned and that the caps and wings are not broken. A slat not aligned with the rest of the cover could jam when the cover is moving and cause major damage.

5. Maintenance advice

In the event of a malfunction or a repair preventing the closure and the securing of the pool, take all necessary measures to prevent the access to the pool of children under 5 years old.

- AS POOL only distributes its technical products via a network of pool professionals which carries out the installation and follow-up depending on the specificities of the pool. AS POOL does not communicate directly with pool owners.
- Have the automatic cover serviced by a swimming pool professional (we recommend your swimming pool installer whose details are on the cover of this manual), who will be able to contact our technical assistance department. All spare parts must be original spare parts in order to maintain our guarantee and the cover's compliance with the standard.
- Each time it is commissioned, the cover should be inspected to identify deteriorations that may compromise its correct operation. A professional will diagnose whether some slats need to be replaced.
- Check that the upkeep advice is applied and that the user carries out his checks regularly. Otherwise go over them item by item.
- Check that the coupling nuts are tightened, that the stop ring and all the screws are present on the axis.
- Check that the electric connections are tight and operate correctly. Make sure there is no humidity or oxidation on the cover's electric contacts (terminals in the box, box connections, contacts of the key switch).
- Check the condition and the ageing of the locking mechanisms and the bungee cords used to retain the PVC slats. Check that the straps are tight on the axis.
- Check the correct operation of the filtering system, the overflow and the water level regulator.
- Carry out several rolling and unrolling tests to make sure the cover is operational and especially to check that the end of run stops are correctly placed.
- When the system does not respond, your installer can secure the pool by uncoupling the cover roller (except for the ZITA model) and manually unrolling the cover onto the pool before locking the safety mechanisms on the pool cover. In this situation the pool cannot be used until the cover is repaired.
- Handling the uncoupling of the roller mechanism should be read thoroughly before operation, with the installation instructions.

1 Switch off the box.

2 Block the roller rotation while keeping the slats rolled around it.

3 For the OPEN range, remove the cover or casing or PVC cap on the motor side. Disconnect wires 1, 2, 3, and 4 of the motor cable in order to slide it completely towards the shaft and remove the unlocking ring.

4 For the BANC, remove the top cover and unscrew the butterfly screw from the housing inside the BANC Solar. Disconnect wires 1, 2, 3, and 4 of the motor cable in order to slide it completely towards the shaft and remove the unlocking ring.

5 For the IMM'Box and the DIVER with the motor in a dry pit: remove the key between the shaft and the motor casing or remove the motor.

6 For the IMMAX, IMMEO, DIVER with axial motor: in the motor connection box located close to the pool, disconnect the limit switch wires and the power wires from the motor cable in order to slide the motor cable completely towards the roller shaft. Remove the pin blocker to access and lift the unlocking pin.

7 Manually accompany the unrolling of the cover, making sure that the motor cable does not jam.

8 Lock the safety mechanisms.

When commissioning the roller, a new adjustment of the motor end of run stops will be needed.

9 "Waste Electric and Electronic Equipment" (WEEE) is the subject of specific collection. It should not be disposed of with your unsorted household waste.



6. Winterisation advice

Winterisation advice is described below, however, it is the installer's responsibility to recommend a solution depending on the availability of the customer and the geographical location of the swimming pool.

- Carry out active winterisation by operating the circulation of the water and filtering during the coldest moments of the day (An anti-freeze thermostat can trigger filtering as soon as the air temperature falls below 0°).
- Keep the water level normal, excess water will drain from the overflow.
- Clean the slats unrolled over the pool using a high-pressure cleaner and then sweep the pool and the storage trench. Treat the water with winterisation products.
- Keep your cover unrolled over the body of water and, if it is surrounded by a lot of vegetation, fit a netting, permeable cover over it in order to avoid the decay of leaves and other plant debris on the PVC slats. Do not store the cover rolled with an accumulation of leaves or debris which would trigger an irremediable decaying process causing encrusted stains to form on the PVC slats. This physical phenomenon is not covered by the guarantee for the slats.
- Protect the skimmers and piping exposed to freezing.
- Protect the motors from flooding.
- Cut the power supply to the electric box.
- Do not operate the cover or touch the slats when they are ice bound. If there is a risk of the pool icing over, have the submerged shaft and the roller motor removed.
- For models using solar power, the batteries can remain in place if the solar panel is not covered and continues its charging function. If the panel is covered and can no longer charge using sunlight, the batteries must be disconnected and stored in a dry place. When putting back into service, let the batteries charge (a half day of sunlight) before operating the cover.

7. Guarantee

Our one year guarantee only covers the replacement or the repair of a defective part as well as all defects or faults in the context of the installation, use, maintenance and winterisation in compliance with our instructions.

It only comes into effect on the shipping date if the reseller or installer returns us the defective parts postage paid for analysis.

The guarantee covers all of the electrical equipment providing that the wiring was carried out in accordance with our instructions and in compliance with the standard C 15.100.

The guarantee does not cover the immersion of motors not designed for this purpose and the consequences of lightning.

Apart from the general one-year guarantee, we grant the following guarantees:

- sending the guarantee form duly completed within 8 days of the slatted cover's installation, gives right to an extension of the geared motor guarantee from 1 to 3 years free of charge
- the roller mechanics: 3 years (1)
- the slatted cover PVC slats: 3 year (2)
- solar panel: 10 ans
- batteries: 1 year.

(1) The guarantee covers the resistance of the materials used with the exception of corrosion and deterioration of certain materials due to the use of any device producing an electro-chemical or electro-physical reaction, which generally accelerates the corrosion of metals.

(2) The guarantee covers the buoyancy, watertightness and articulation of the slats. The guarantee does not cover brownish stains and discolouration of the slats. Distortion of the blue translucent solar slats caused by use in disregard of our technical recommendations is also excluded. Damage caused by hail is excluded. All modifications to a slat voids the guarantee on the apron.

All labour costs for removal, assembly, travel, water supply, products, damages and interests as well as any claims for compensation for any cause whatsoever are excluded.

Guarantee

The official guarantee is in the slatted cover's container with the commissioning documents. This guarantee must be returned to the address below within eight days of the commissioning of the product.

User details

Name:

Address:

Postcode/Town

--	--	--	--	--	--	--

Installer details

Company:

Address:

Postcode/Town

--	--	--	--	--	--	--

Installed model			
Serial N° _____ / _____ / _____			
Slatted cover type	Slatted cover slat colour		
<input type="checkbox"/> MANU <input type="checkbox"/> OPEN Néo <input type="checkbox"/> OPEN Classic <input type="checkbox"/> OPEN AERO <input type="checkbox"/> OPEN DSIGN <input type="checkbox"/> OPEN SURF System <input type="checkbox"/> OPEN Solar Energy	<input type="checkbox"/> BANC Classic <input type="checkbox"/> BANC SURF System <input type="checkbox"/> BANC Solar Energy <input type="checkbox"/> BANC D.sign <input type="checkbox"/> IMM'Box <input type="checkbox"/> IMM'Ax <input type="checkbox"/> DIVER	<input type="checkbox"/> White PVC <input type="checkbox"/> Sable PVC <input type="checkbox"/> Blue PVC <input type="checkbox"/> Light grey PVC <input type="checkbox"/> Galet grey PVC <input type="checkbox"/> Blue-tinted two-ply PVC	<input type="checkbox"/> Clear polycarbonate <input type="checkbox"/> Blue-tinted translucent polycarbonate <input type="checkbox"/> Blue-tinted two-ply polycarbonate <input type="checkbox"/> Mother of pearl tinted two-ply polycarbonate <input type="checkbox"/> Clear/black two-ply polycarbonate <input type="checkbox"/> Black fumée polycarbonate

MANDATORY INFORMATION FOR VALIDATION OF THE GUARANTEE

Checks carried out on commissioning by the installer

Checks carried out by:

	Yes	No
Checks carried out by:	<input type="checkbox"/>	<input type="checkbox"/>
Installation carried out in compliance with the standards in force according to the manufacturer's instructions:	<input type="checkbox"/>	<input type="checkbox"/>
12 or 24 volts (slatted covers):	<input type="checkbox"/>	<input type="checkbox"/>
Presence of an automatic water level regulator (slatted cover):	<input type="checkbox"/>	<input type="checkbox"/>
Presence of an independent overflow:	<input type="checkbox"/>	<input type="checkbox"/>
Rolling operation (slatted cover):	<input type="checkbox"/>	<input type="checkbox"/>
Unrolling operation (slatted cover):	<input type="checkbox"/>	<input type="checkbox"/>
Locking of the pool cover (slatted cover):	<input type="checkbox"/>	<input type="checkbox"/>
Installation without reserves:	<input type="checkbox"/>	<input type="checkbox"/>
Commissioning date:		
Safety, usage, upkeep and maintenance advice explained and sent to the responsible user:	<input type="checkbox"/>	<input type="checkbox"/>

Signature and stamp (mandatory)

(write the words
"read and approved")

Comments/Observations:

.....

.....

.....

Operational check

SYMPTOMS

- 1** The roller does not rotate
- 2** The cover rubs against the sides, under the coping and on the separation
- 3** The cover does not roll completely or rolls too far
- 4** The cover does not unroll completely or unrolls too far

1	2	3	4	MAKE THE FOLLOWING CHECKS:
✓				230 V power supply to the electric box (check the 10A/30mA ground fault circuit breaker)
✓				The on/off button on the box is ON
✓				Fuses are in good condition
✓				12 V or 24 VDC voltage on the motor power terminals when the key is turned
✓				Continuity of contacts of the key switch when the key is turned
✓				12 V or 24 VDC polarised voltage on the 2 motor power wires in the connection box when the key is turned
✓				The wire connections in the connection box are in good condition, tight and not oxidised
✓		✓	✓	Adjust the run stops
✓		✓		The safety mechanisms are unlocked
✓	✓	✓	✓	There are no objects in the pool that could prevent the correct operation
	✓			The apron is centred
	✓		✓	The water level is compliant with the recommended level and is constant
	✓	✓		The sides of the pool are level and parallel
✓		✓		The slat apron is attached to the shaft
	✓		✓	No slats are damaged or out of alignment

SERVICING OF THE EQUIPMENT	
Date	Type of work
.....
.....
.....
.....
.....
.....
.....
.....
.....
.....
.....
.....
.....
.....
.....
.....
.....
.....
.....
.....
.....

Product: SLATTED COVER line
 Company: AS POOL
 Address: ZAC de la Rouvelière
 F-72700 SPAY- LE MANS
 Phone: +33 (0)811 901 331
 Fax: +33 (0)243 479 850
 contact@abriblue.com
 www.abriblue.com

