



HPP Heat pump HPP6, 8, 12, 15, 20

EN Installation manual
Rev. 1.0

Dantherm[®]

CONTROL YOUR CLIMATE

Introduction

Introduction!

This is the Installation manual for the Dantherm HPP Heat pump.
 Your Dantherm HPP heat pump has been specially designed for pool heating using high quality components, carefully chosen to provide maximum efficiency and reliability. Please read this manual carefully as it provides useful installation, operation and maintenance information that will maximise the benefits your HPP heat pump will offer.
 Please see the below table of content for further information about the sections.
 The HPP heat pump is made in China.

Product numbers

This Installation manual covers the following products:

Name	Product number
HPP 6 Heat pump:	351701
HPP 8 Heat pump:	351702
HPP 12 Heat pump:	351703
HPP 15 Heat pump:	351704

Instruction manual product number

Product number for this instruction manual: 096982

Target group

The target group for this service manual are the technicians who install and maintain the Dantherm HPP heat pump, as well as the users of the unit.

Copyright

Copying of this service manual, or part of it, is forbidden without prior written permission from Dantherm A/S.

Reservations

Dantherm reserves the right to make changes and improvements to the product and the service manual at any time without prior notice or obligation.

Table of contents

Topics	Page
Introduction	2
Product description	3
Safety Precautions	5
Installation	6
How to use the HPP heat pump	12
Wiring diagrams	16
Maintenance	21
Trouble shooting	22
Error codes	23
Technical Data, parameter list and dimensions	24
Water Quality	30
Contact Dantherm	32

Product description

Introduction!

This section describes the overall product, and its functionality

Usage of the HPP Heat Pump

The Dantherm HPP range of air to water heat pumps is designed for swimming pool and Spa heating and consists of 4 sizes. HPP heat pumps are designed to heat pool water and spas within a water temperature range of +15°C to 40°C.

Every model within the HPP range can operate in outside temperatures from +3°C to +35°C.

The water heat exchanger is a full flow type, manufactured from titanium tube, which is a highly corrosion resistant material.

The heat pumps are suitable for use in fresh water and salt water pools.

HPP 6, 8 and 12 heat pumps are fitted with rotary compressors.

The HPP 15 heat pump is fitted with a scroll compressor.

Both types of compressor are for known long service life, efficiency and quiet running.

A 3 minute compressor start delay timer is incorporated for compressor protection.

With these features the heat pump is designed to have a long, trouble free life.

All HPP units have integral safety devices to protect the heat pump from internal and external faults.

The touch screen user interface displays the operating mode. The digital thermostat within the user interface controls the water temperature.

Important

Dantherm A/S recommends that the heat pump should be powered continuously!

HEALTH AND SAFETY WARNING



This appliance can be used by children from eight years and above and persons with reduced physical, sensory or mental capabilities or lack of experience and knowledge if they have been given supervision or instruction concerning the use of the appliance in a safe way and understand the hazards involved. Children should not play with the appliance. Cleaning and maintenance shall not be made by children without supervision.

Disconnect from the mains supply and wait three minutes before removing panels and commencing work on this machine.

Function

The Heat Pump Cycle

The Dantherm HPP Swimming pool heat pump provides thermodynamic heating by means of a vapour compression cycle, (similar to that employed in a conventional refrigerator), in addition to acting as an active solar collector.

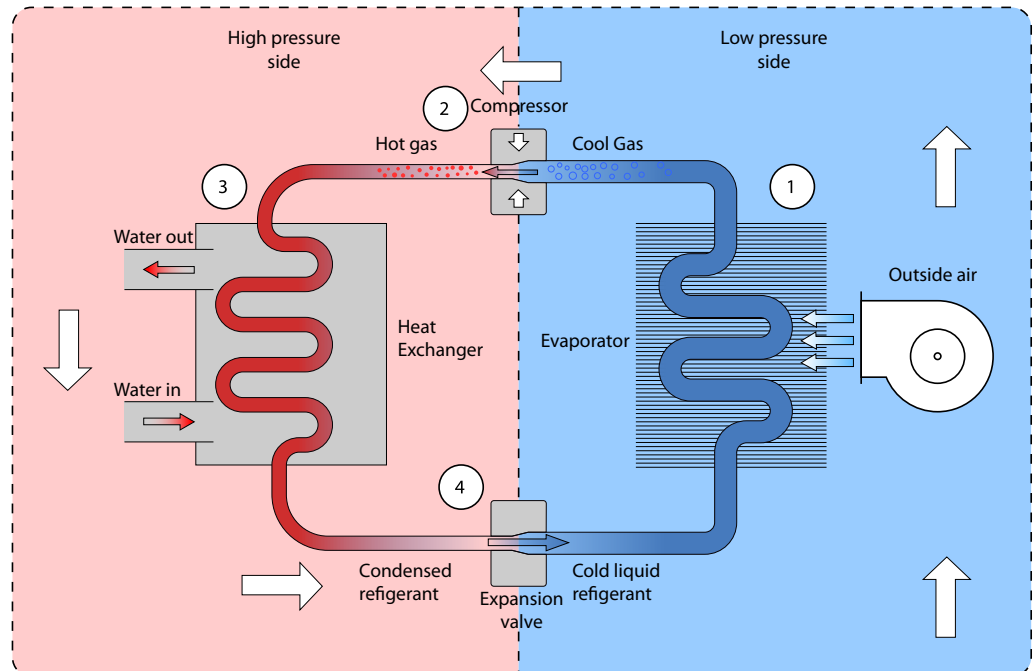

1. **The evaporator** collects sensible and latent heat from outside ambient air, pre-heated by the sun. This process is enhanced by an internal fan that forces large quantities of air across the evaporator.

The evaporator consists of a series of finned tubes, which have cold liquid refrigerant passing through them. They are capable of extracting energy from the ambient air that passes across them. In doing so, the ambient air gives up its heat to the refrigerant which then vaporizes. This preheated vapour now travels to...

2. **The compressor** where it is compressed and upgraded to a useable form of heat. The hot vapour now enters...-

3. **The Condenser** where it is surrounded by the pool water. The heat is given up to the cooler pool water and the now cold refrigerant returns to its former liquid state but still under high pressure from the compressor.

This pressure is released by passing the liquid through... -

4. **The Expansion valve** and from there, now at low pressure and temperature, it is returned to the evaporator and the cycle starts again.

Coefficient of Performance

The efficiency of a Heat Pump is called its 'Coefficient of Performance' - (COP) which is simply a ratio of heat output to energy input, both being expressed in kW. Thus a Heat Pump absorbing 1 kW of electricity, collecting 4 kW of energy from the air, and delivering 5 kW of heat to the pool water is said to have a COP of 5.

This ratio will vary according to the temperature of the water and the ambient air.

Safety Precautions

Installation

- Ensure that the heat pump on site is as ordered, i.e. model, electrical supply.
- Inspect the unit for damage, in particular inspect the evaporator (finned side) to ensure that it is undamaged. (Minor indentations in the fins do not affect performance). If severely damaged, endorse the delivery note in the presence of the driver and send a recorded delivery letter to the transport company giving details.
- Protect the unit if installation is delayed.

Siting

- Provide a firm level base capable of supporting the weight of the unit; spread the load if mounted on a timber floor.
- Ensure that water cannot collect under the unit, it is recommended that units are installed on plinths 100mm above finished floor level. This also aids condensate drainage.
- Please allow adequate clearance to service panels on the unit; recommended 500mm minimum.
- The HPPs are by design as quiet as is practical, however due consideration should be given to siting the HPP in order to minimise the effect of noise coming from the HPP, for example by positioning the HPP so that the inlet/outlets are parallel to occupied premises.
- Ensure loose debris such as leaves, grass cuttings, etc. will not block air inlet grilles.
- Consider protection from extreme weather conditions if installed externally near to sea spray etc., i.e. lean-to-cover or open walled building.
- Use the anti-vibration feet provided, these help to reduce the noise from the HPP and also help to prevent corrosion to the base of the HPP. The use of stainless steel fixings is recommended.

Warning



- Always ground the unit
- Securely connect the electrical power
- Do not install the product in a high place with the risk of it falling down.

Installation requirements

Incorporate the following when installing the electrical connections:

- DC external supply should be protected with an external circuit breaker at 35 Amps
- Label disconnected devices, stating rated voltage and rated current.
- It is imperative to secure and install all connections to prevent any damage to equipment and/or humans.
Secure all cables with cable ties or appropriate cable fasteners.

Operation

WARNING

- Make sure all power is disconnected prior to installation, maintenance or service.
- Do not allow water to run into electrical parts
- Do not place obstacles around the air flow inlet or outlet

Installation

Siting, unit location and airflow

Due consideration must be given to air flow i.e. do not obstruct inlet or outlet and ensure discharge air cannot recirculate to inlet. (See below).

Suitable openings:

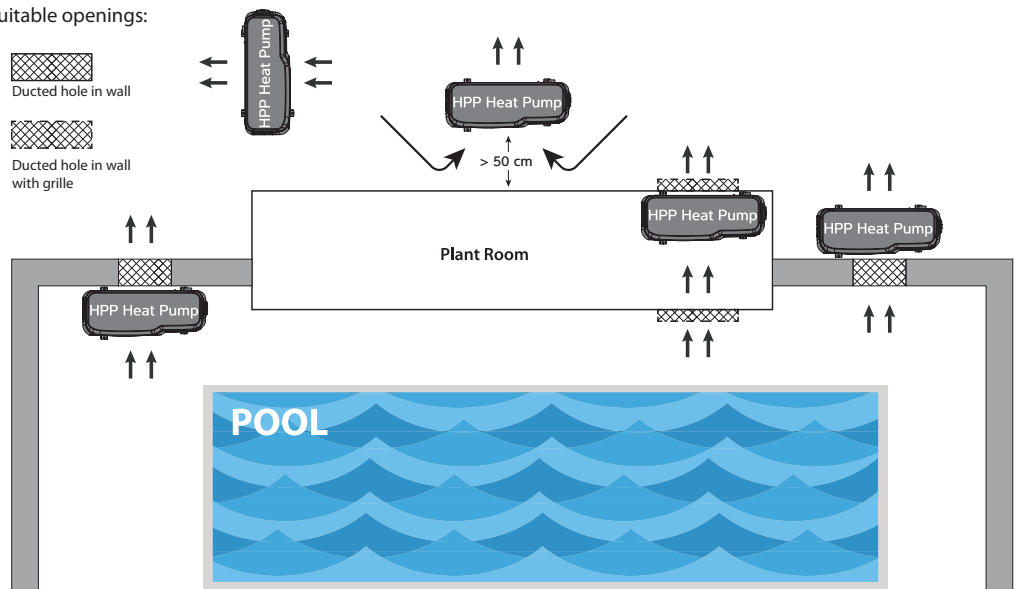

Required Free Areas

Required Free Areas to provide air flow to and from heat pumps when installed in an enclosed area or where required to pass air through a wall etc.

Free areas is the available area through which air can pass through a grille or louvres.

MODEL	Minimum Free Area m ²	
	Inlet	Discharge
HPP 6	0.313	0.13
HPP 8	0.313	0.13
HPP 12	0.422	0.17
HPP 15	0.422	0.17

Important!

If multiple units are installed in an enclosed area then the inlet free areas required for each unit can be added together to form one inlet aperture.

BUT discharge from each unit must be kept separate and cannot be incorporated into one common duct system.

Plumbing installation

Installation

- The HPP has water inlet/outlet plastic water connections and can be connected to either 1 1/2" or 50mm plastic pipe.

- The HPP must be connected after the filter in the return pipe to the pool. If an existing heater is being retained, then the HPP should be connected between the filter and the other heater. (See recommended plumbing schematic).

- Suitable breakable couplings should be installed local to the heat pump.

If the heat pump is installed at a lower level than the pool then isolation valves should be fitted.

A drain valve or plug should be fitted to the lower pipe to facilitate draining water in the winter period. Connections on all HPPs are via either 1 1/2" or 50mm plastic pipe. The pipes need to be glued into the water in/out connections with a suitable adhesive.

Condensate fitting

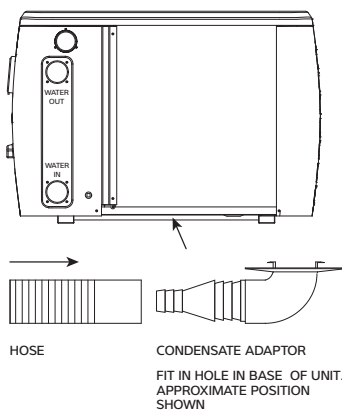

- The condensate drain in the base of the HPP collects condensation from the evaporator fins.

The condensate should run away to waste using the flexible drainage tube provided. To aid drainage the HPP should be placed on a level plinth so that the condensate water can run away and not overflow the edges of the drip-tray inside the unit. The position for fitting the condensate adaptor is in the base of the unit. It will be easier to fit this and the hose BEFORE the HPP heat pump is connected to the water supply.

- When the pipework installation is complete the pool circulation pump should be switched on and the system tested for leaks. Also check the filter gauge to see that there is not an excessive increase in back pressure. If everything is then working normally the water circulating system is ready for use.

- The water circuit to and from the unit is to be capable of maintaining, within specified limits, the rate of flow required by the HPP. (See HPP DATA SHEET on page 24)

All pipework must be adequately supported with allowance for expansion or contraction, especially with plastic pipework.

- It is recommended that when installing water systems, that the last connections to be made in the system should be breakable connections to avoid any stresses on the water connections at the HPP.

Important

- All pool purifying devices and chemical injection systems must be fitted downstream of the HPP with a non-return valve to prevent concentrated chemicals back feeding into the heat exchangers.

- The practice of dosing chemicals direct into skimmer basket must not be allowed as this would result in concentrated corrosive liquids passing over vulnerable metal components.

- Water quality must be maintained not only relating to solids, etc. but for pH between 7.4 - 7.8, and if pool water is saline at a maximum concentration of 8mg/litre.

- The maximum pressure of water in the HPP circuit should not exceed 3kg/cm (50psi)

Acidity pH	pH	7.4 - 7.8
Total Alkalinity, as CaCO ₃	ppm	80 - 120
Total Hardness, as CaCO ₃	ppm	150 - 250
Total Dissolved Solids	ppm	1000
Maximum Salt Content	ppm	8000
Free Chlorine Range	ppm	1 - 2 Domestic
Free Chlorine Range	ppm	3 - 6 Commercial
Superchlorination	max	30ppm for 24 hrs
Bromine	ppm	2 - 5
Baquacil	ppm	25 - 50
Ozone	ppm	0.9 Max
Maximum Copper Content	ppm	1
Aquamatic Ionic Purifier	ppm	2 Max

Recommended plumbing schematic

Recommended plumbing schematic

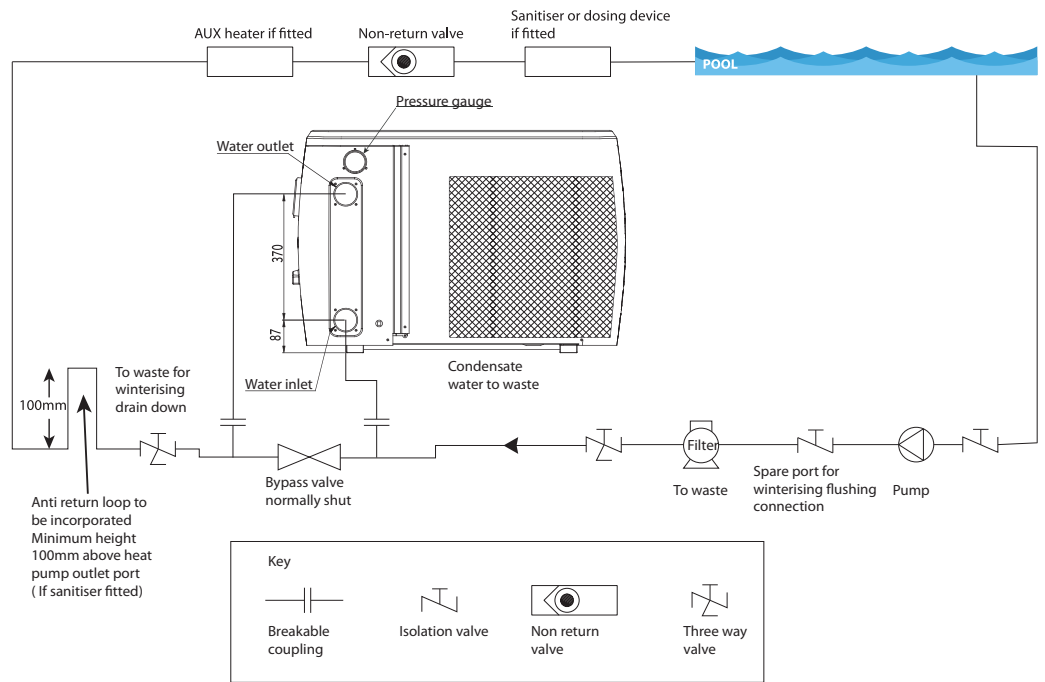

Determining the water flow

The HPP heat pump is fitted with a water flow switch which inhibits the operation of the unit when the water flow is less than that shown in the table below.

HPP Heat pump	Minimum flow rate
6	2400L/hour
8	3360L/hour
12	4320L/hour
15	5760L/hour

Error code PL on the user interface will be shown until the correct flow rate is achieved. Once this error code is extinguished the flow rate is adequate. See Technical data for HPP for correct water pressure drop.

Electrolytic corrosion

Electrolytic corrosion will occur when dissimilar metals that are in contact with each other create a potential difference (voltage) between them. Sometimes, when separated by a conductive substance known as an electrolyte, the dissimilar metals will create a small voltage that allows the ions of one material to pass to the other.

Similar to a battery, ions will pass from the most positive material to the more negative material. A voltage of more than 0.3 volts can cause the most positive material to degrade.

A swimming pool with its associated equipment can create this effect. The pool water being an ideal electrolyte and components of the filtration circuit, heating system, steps, lights etc. providing the dissimilar metals needed to complete the circuit.

Whilst these small voltages are rarely a safety threat, they can create premature failure through corrosion. Not dissimilar to corrosion through oxidation, electrolytic corrosion can cause complete failure of a metallic material in a very short period of time.

In order to prevent this type of corrosion all metallic components in contact with swimming pool water should be bonded together using 10mm² bonding cable. This includes non-electrical items such as metal filters, pump strainer boxes, heat exchangers, steps and handrails. It is strongly recommended that bonding be retrofitted to existing pools, which may not be protected by this system.

Electrical installation

Electrical safety

It is important to ensure that all aspects of the installation comply with the latest I.E.T. Regulations or local codes of practice as applicable.

The machine should be installed in accordance with EMC 2004/108/EC

Protected supply

Whilst not mandatory, Dantherm recommend that an R.C.C.B. is always fitted or that the supply is to local electricity authority recommendations, and that all ducting is bonded in accordance with these regulations.

The supply to the machine should incorporate fuses or motor rated circuit breakers (Type C) to specified rating, (See Technical specifications for HPP on page 24

H.R.C. fuses are recommended. An isolator must be fitted within clear view and not more than 2 metres away.

The isolator must have a minimum 3mm air gap in the off position.

All units must be correctly earthed/grounded. An earth leakage trip is recommended to be fitted to all pool electrics.

Important

The user should be made aware that:

The whole installation should be isolated when working on any part of the installation.

Inconsistent electrical supply

The following limits of operation must not be exceeded if Dantherm machines are to be guaranteed either in performance or warranty terms:

Voltage	Minimum	Maximum
Single phase machines	207V	253V
Frequency	47.5Hz	52.5Hz

Note: The voltage must be measured at the HPP mains terminals with all the fans/compressors running at the rated load condition.

Correct cable sizing

The cable supplying electricity to a machine with a given load must increase in cross sectional area (C.S.A) as the length increases in order that the voltage drop within the cable does not exceed recommended limits.

Cable sizing should be calculated by an approved electrician with due consideration to I.E.E and local codes of practice.

HPP Heat pump	Minimum Cable Size
6	2.5mm ²
8	2.5mm ²
12	4mm ²
15	6mm ²

Warning: It is necessary to wait three minutes after the supply is disconnected before removing any panels or commencing servicing of the HPP heat pump.

Location of mains input

- Undo the screws and remove the panel covering the cable entry point on the HPP.
- Run a correctly sized piece of power cable through the cable entry point shown in the view below.
- Connect the power cable to the terminals behind the panel then replace the panel and secure it with the screws.

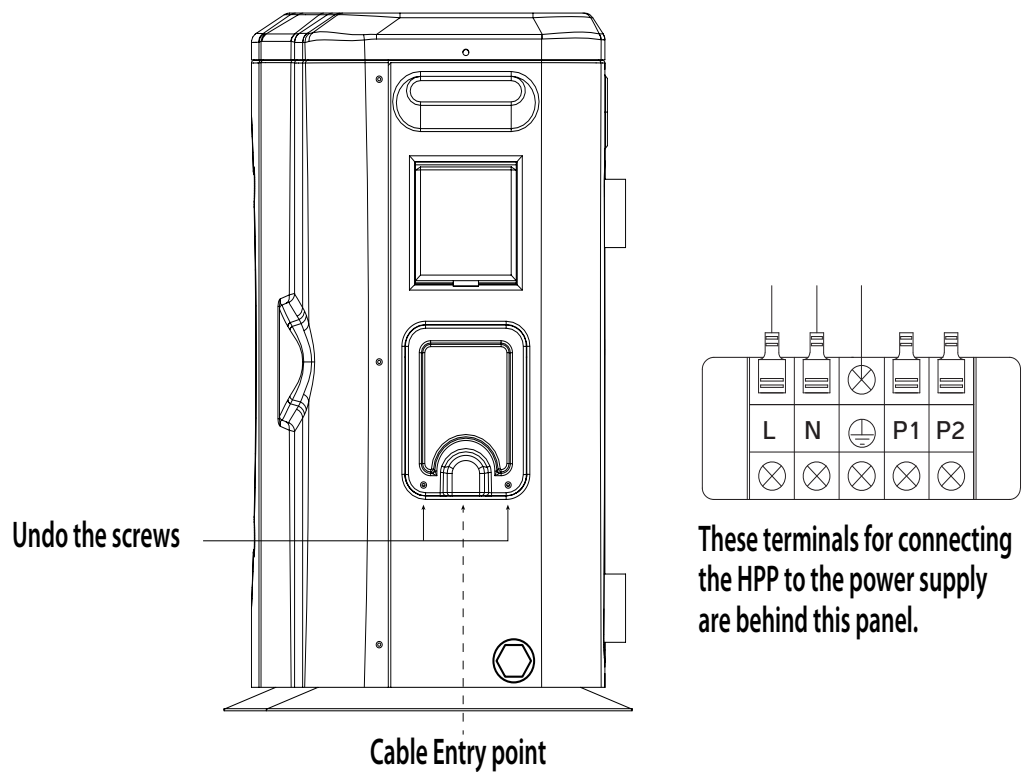

Pool pump synchronisation

Pool pump synchronisation

For installations where the filter pump, which also provides water to your HPP, is controlled by a time clock (supplied by the installer) your HPP can over-ride "pump off" periods set on the time clock so that the filter pump will run if your swimming pool requires heating. By doing so your filter pump will only run when:

- a) A block period of pump "running" has been set on the time clock for filtration purposes.
- b) The pool requires heating.

This feature operates by overriding the filter pump time clock for three minutes each hour so that water is pumped through the HPP

If during this sampling period the heat pump detects a need for water heating it will continue to over-ride the time clock until the swimming pool temperature is satisfied. If water heating is not required, the filter pump will turn off after the three minute sampling period and not restart until the next hourly sampling period or time clock pre-set run time. This feature will reduce the filter pump run time and consequently save energy as well as unnecessary filter pump wear and tear.

Schematic

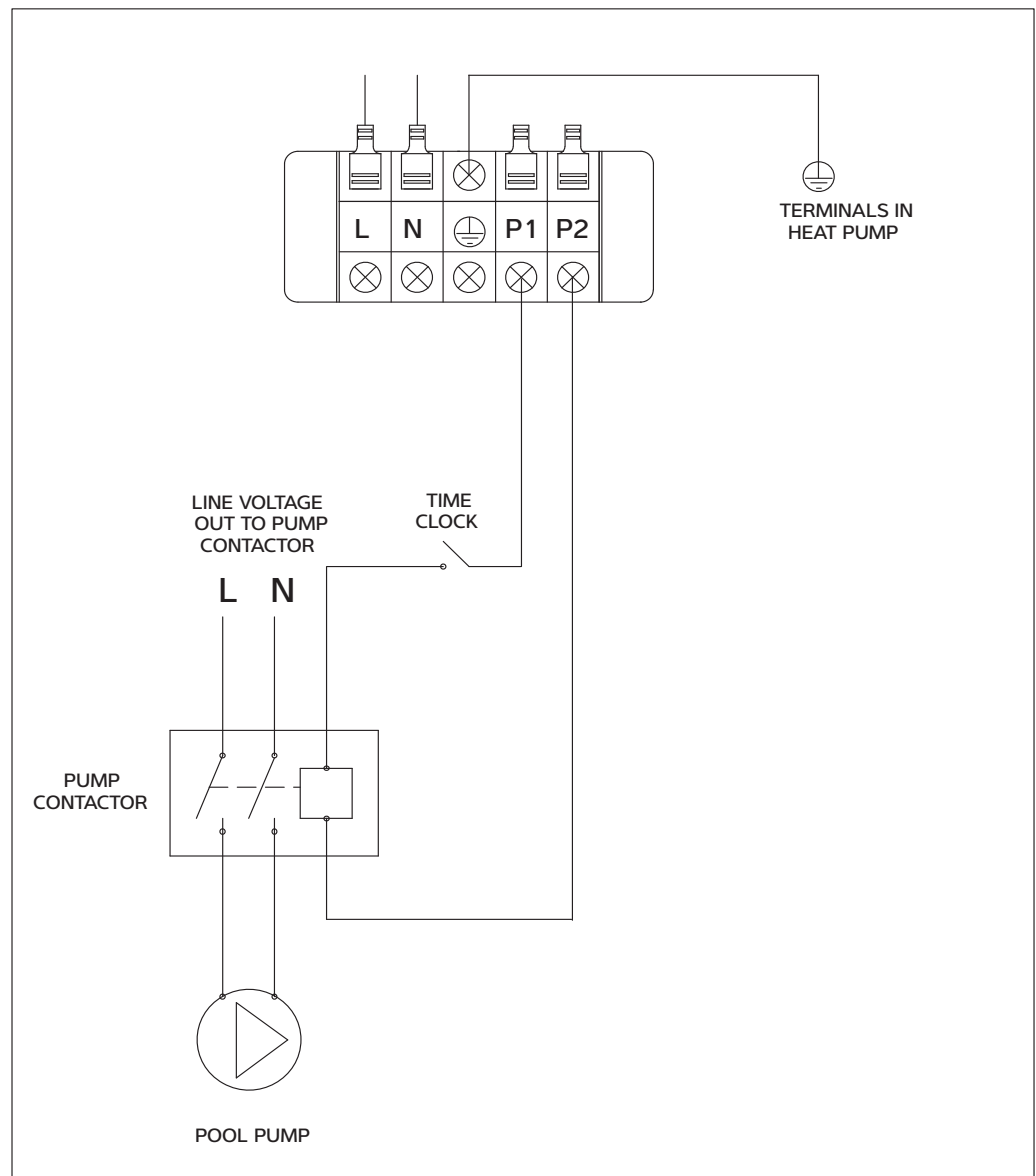

How to use the HPP heat pump



Touchscreen user interface

Display of operating condition and access to settings.

Caution

– the HPP system remains powered and live. Ensure the HPP is isolated from the power supply before any servicing or electrical work commences.

Touchscreen user interface

Controller

The HPP is controlled by an integral controller with a touchscreen user interface. The basic functions are: Heat pump ON/OFF, 24 hour time clock, Timer On/Off, parameter adjustment. Please note that the HPP will only run when it has been connected to the water supply.

Home screen

This screens display current operating conditions and main controls.

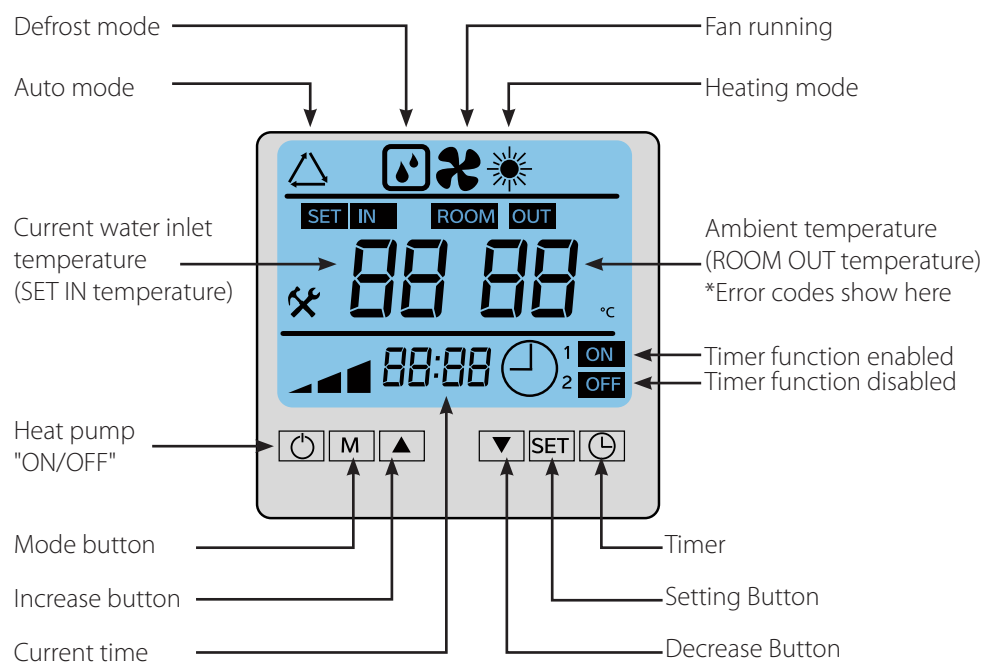

Turn the HPP heat pump on and off.

Turn HPP Heat pump on

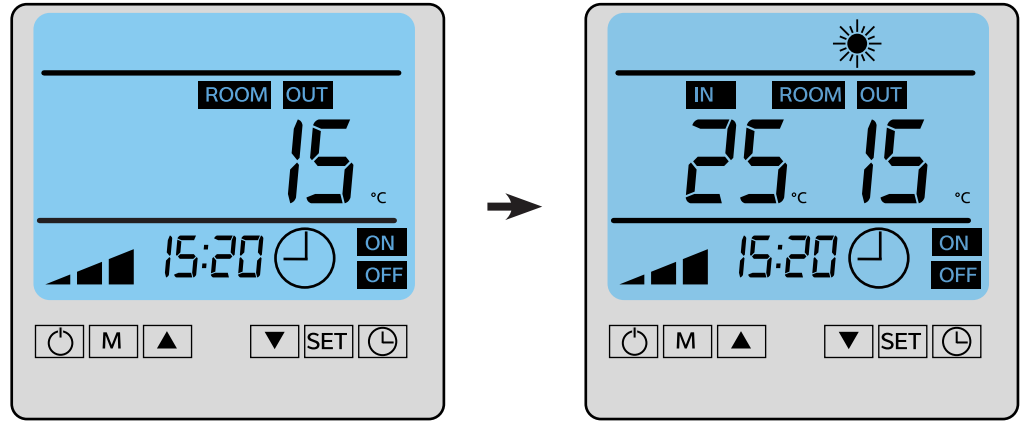

When the HPP is off press  to turn it on.

Turn HPP Heat pump off

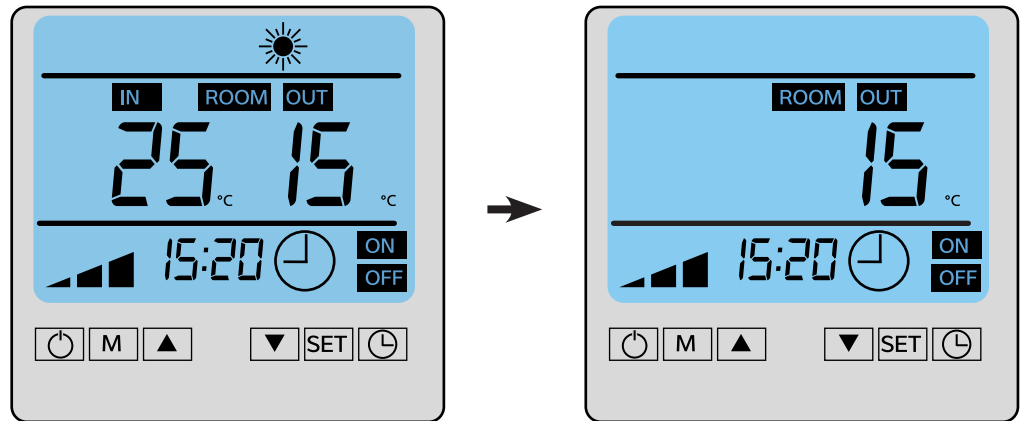

When the HPP is on press  to turn it off.

Change the temperature.

Change the temperature.

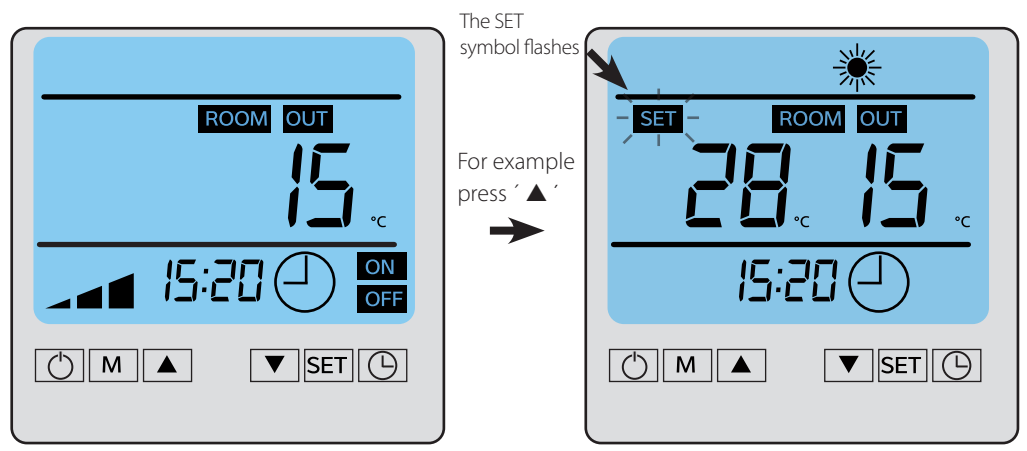

Example

When the HPP is on, press the  or  button to change the temperature setting.

Functions of the buttons on the user interface.

Important.

Remember that at startup there is a 3 minute time delay before the HPP heat pump starts

Unit ON/OFF button



Press this button when the unit is in standby mode. The HPP can be turned 'ON' and run in the setting mode. When the HPP is in the running mode, temperatures, timer setting and clock times are displayed on the screen. Press this button again when the HPP is running and the HPP will then be turned 'OFF'.

Mode button



Press this button to select the running mode at any point. Each time this button is pressed, the mode will change in the sequence below:

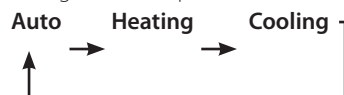

Notes:

1. Parameter 13: Unit mode selection decides the HPP running mode. When set at "0", the HPP is in cooling mode, and if set at "1", 3 modes are available: Auto, Cooling, Heating. If set at "2", only heating is available. The HPP supplied is for heating only.

The adjust buttons





These are the multi-purpose buttons. Combining these with the **SET**, **M**, and  buttons, they are used for parameter setting, parameter checking, and timer adjustment.

On main running interface, press   to adjust the setting temperature.

The setting button



This is a multi-purpose button.

Combining with the   and **M** and  buttons, they are used for parameter setting, parameter checking, and adjustment of the timer.

Icons on the touchscreen user interface

Heating mode



This icon indicates that the current operation mode is heating.

Defrosting



This icon indicates that the defrosting function is enabled. This is an automatic function where the unit will enter or exit defrost cycle according to the inner control program. The defrost parameters can be altered. The unit does not have a manual defrost option.

Left temperature display



This display shows the current water inlet temperature.

If you want to check or adjust the parameters, this section will show the relating parameter number. In a malfunction occurs, this section will show the related error code.

Right temperature display



This display shows the ambient temperature.

If you want to check or adjust the parameter, this section will show the related parameter value.

Clock display



The clock display shows the current time.

When reading or programming the timer settings, the clock display shows the set times.

Timer 'ON'



This icon indicates that the timer 'ON' function is enabled.

Timer 'OFF'







This icon indicates that the timer 'OFF' function is enabled.









Controller operations

Parameter checking and setting.



Press the  button for 10 seconds to enter the parameter checking interface, then press  to enter the parameter settings menu. You can now adjust parameters value with the  and  keys. Press  to save and switch to other parameter settings.









Notes:

- Press the  button for 10 seconds to enter parameter checking and adjusting status.
- Press  to switch to different parameter checking.
- Press  to enter into the parameter settings status, and change parameter values with , . Press  to save and switch to other parameter settings.
- Under parameter checking status, press   to exit parameter checking status.
- You can check and adjust the set parameters during standby mode; you cannot adjust the parameters when the unit is running.

Parameter settings will be invalid if the power fails within 10 seconds of making an adjustment.











Setting the time and timers.



Press the  directly to enter timer settings. The clock icon  will flash, then press  to set Hour with the   press again to set Minute with   then press  to save and complete settings. If not required, press to enter into the next group of timer settings.

Notes>

Three daily timers can be set but each timer needs to a set ON and OFF time.

Press  directly to enter Timer Settings. The icon  will flash, then press  to set Hour with   and press  again to set Minute with  . If you need to cancel Timer Settings, please press  and "-- : --" will display. Press  to save and enter into the next group of timer settings. If you do not want to save data, please press  to enter into the next group of timer settings.

Wiring diagram

HPP Heat pump 6

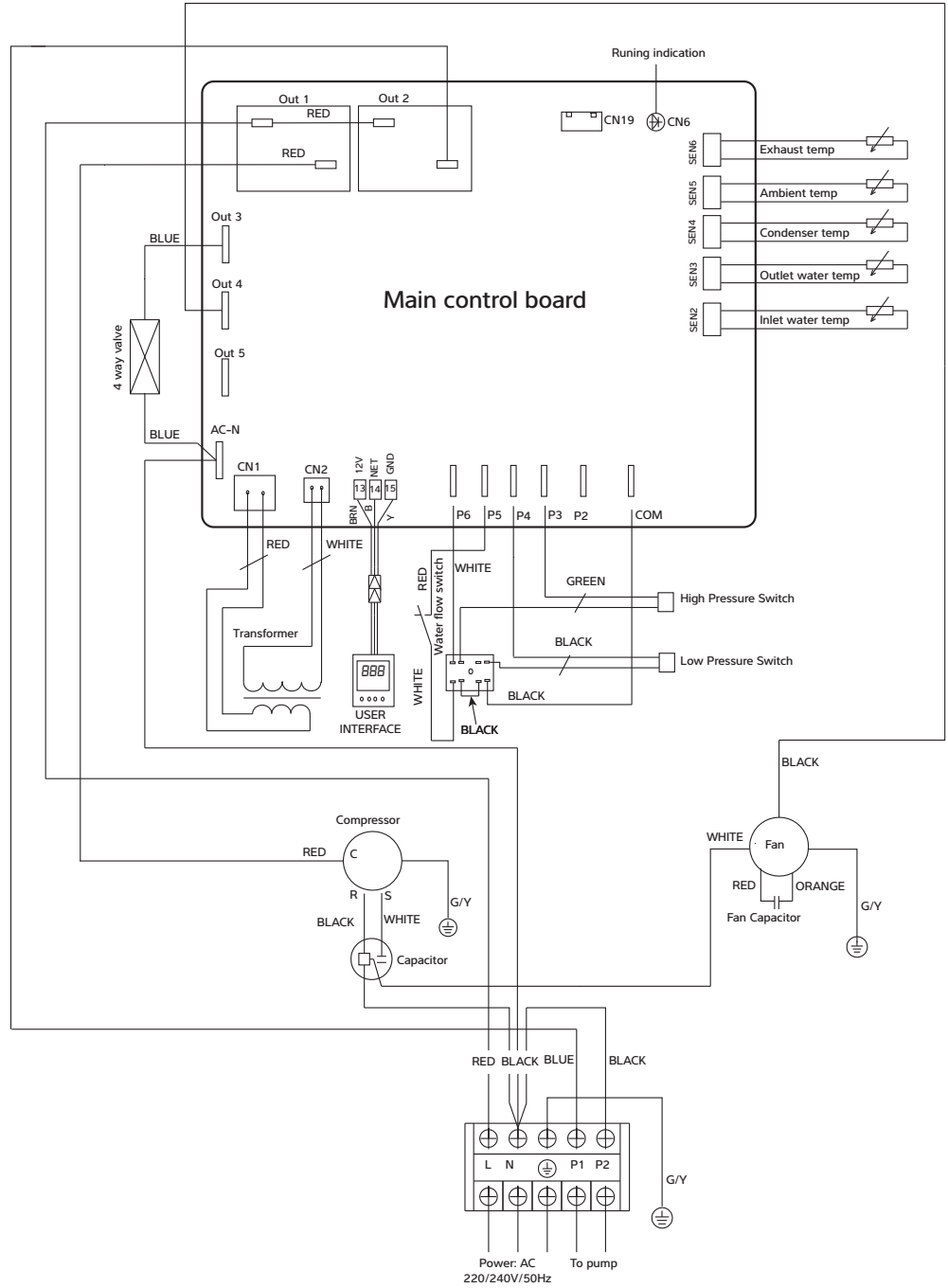

Wiring diagram

HPP Heat pump 8 and 12

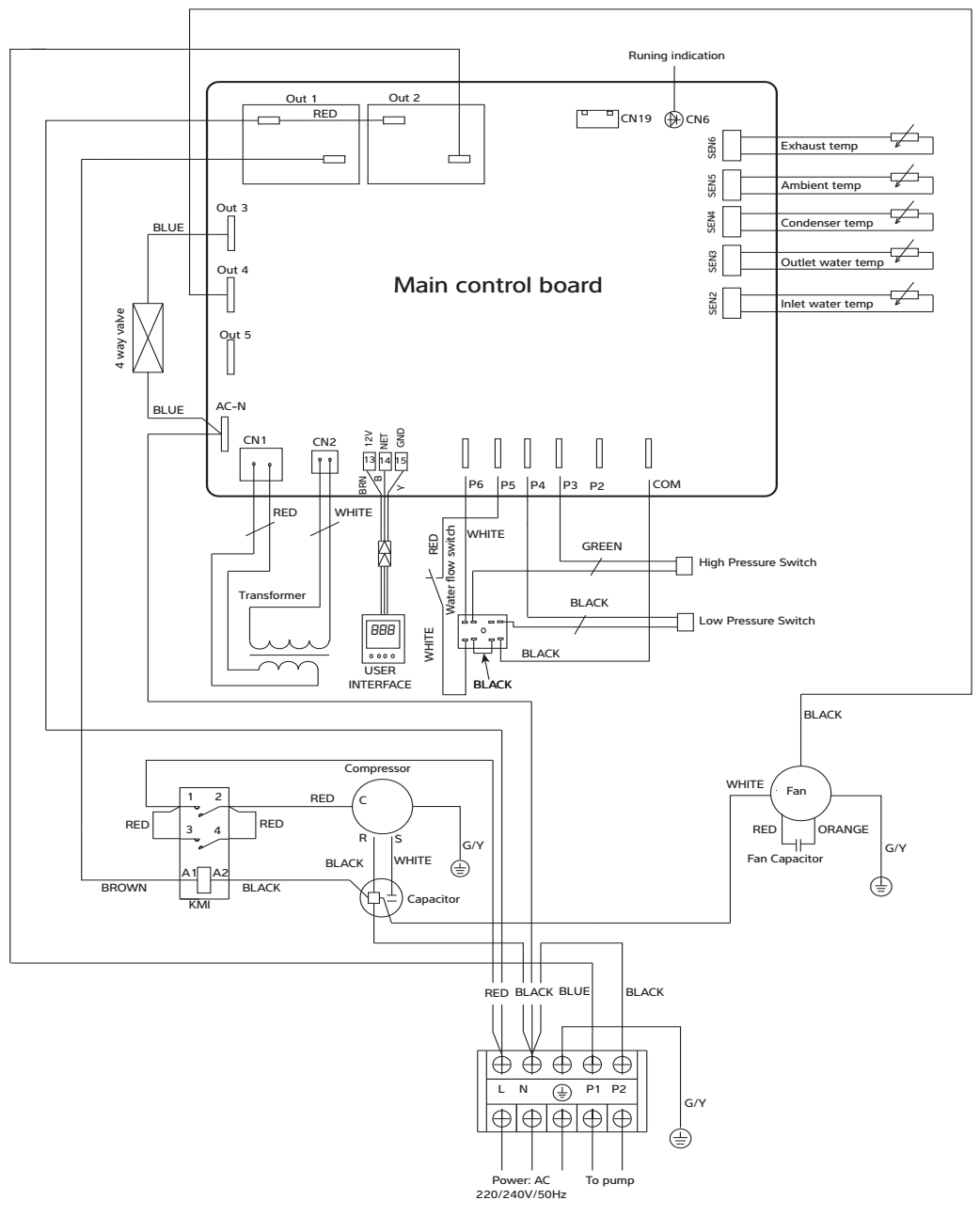

Wiring diagram

HPP Heat pump 15

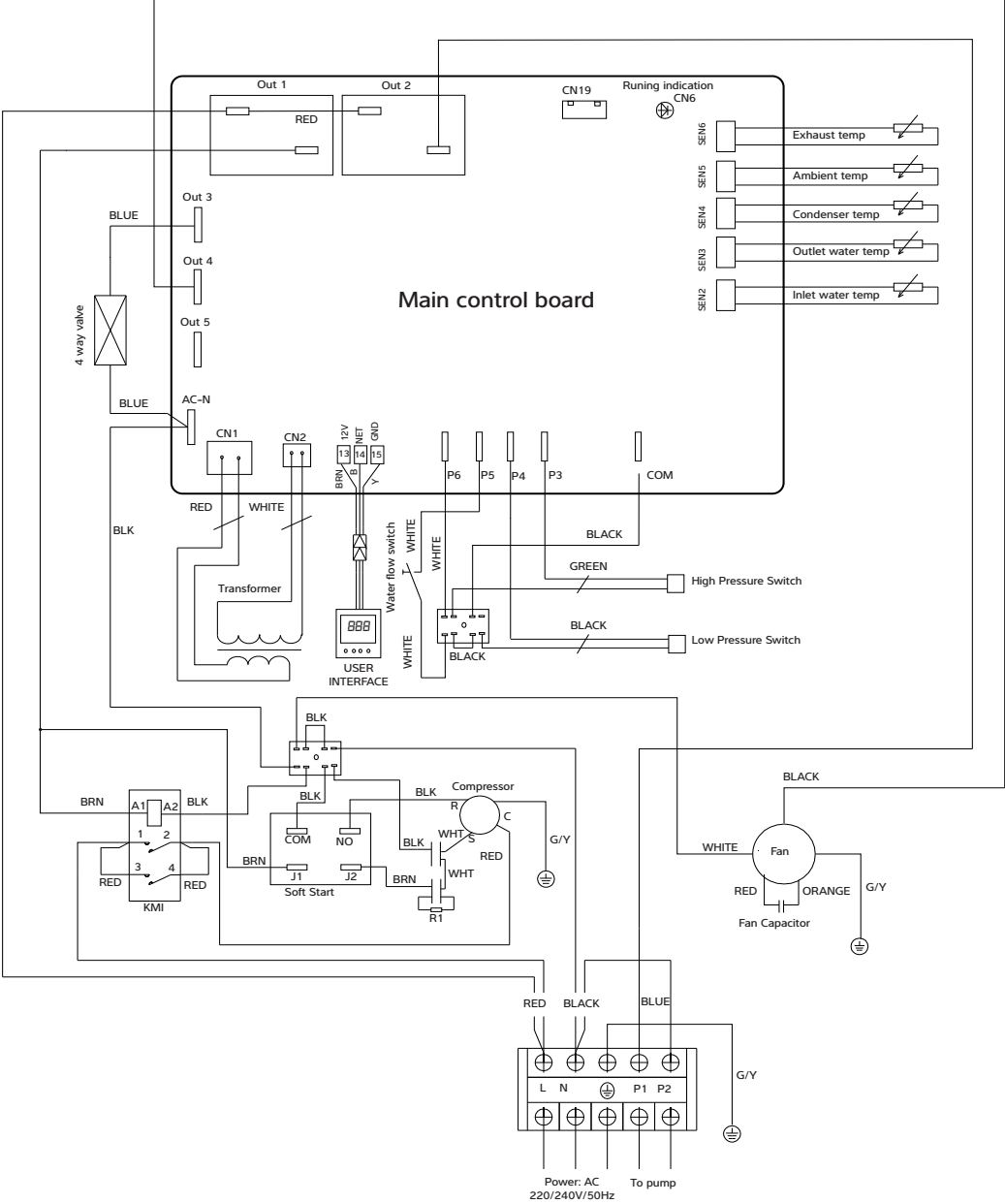

Maintenance

Operations carried out during a planned maintenance visit:

- Check operation and condition of all fans and compressors.
 - Check capacitor tolerances.
 - Check condition of all heat exchangers/evaporators.
 - Check refrigeration system parameters.
 - Check operation of control valves.
 - Check for water leaks.
 - Check drip trays and internal drain lines for blockages and clear.
 - Check operation of controls and calibrate as necessary.
 - Check operation of interlocks in use.
 - Final check on overall operation of unit.
 - Indicate on report any faults found or causes for concern.
-

Frequencies recommended are as follows:

Light/Medium use: 1 visit per year

Heavy use: 2 visits per year

Heat pump malfunction - Troubleshooting

WARNING: Isolate heat pump electrically before entering heat pump or removing panels.

Refer to the user check list and the error codes listed in section 7.2 before initiating a service call.

Do not attempt to interfere with any internal control settings as these have been factory calibrated and sealed.

Any sign of abnormal operation such as water dripping should be reported immediately to an installer. If in doubt or if advice is required contact the Service Department.

Problem	Cause	Remedy
The HPP will not run	Power failure	Restore power to HPP
	Tripped MCB/ Faulty fuse	Reset MCB or replace fuse
	User Interface switched off	Switch on the User interface
	Temperature of pool water incorrectly set	Re enter a correct value for the water temperature
Set Temperature level cannot be reached	Air temperature set too high or too low	Re enter a correct value for the water temperature
	The air inlet or outlet is blocked, restricted or very dirty	Clean the inlets with a brush
	Closed valves or stop cocks in the water pipes	Check the water circuit and open any valves that are closed.
The timer works but the programmed actions do not run at the expected times	The clock and the day of the week are not set correctly	Adjust the timer.

Error codes

When an error occurs or a protection mode is set automatically, the user interface will display an error code as shown below.

Code	Problem	Cause	Remedy
P1	Coil temperature sensor failure	1) Sensor open circuit	1) Check sensor connection
P2	Compressor exhaust gas temperature failure	2) Sensor short circuit	2) Replace the sensor
P3	Inlet water temperature sensor failure	3) Main PCB damaged	3) Replace the main PCB
P4	Outlet water temperature sensor failure		
P6	Protection for over high inlet/outlet water temperature difference	1) Water flow low	1) Check that the water filter and water circuit are not blocked
P7	Ambient temperature sensor failure	2) Main PCB damaged	2) Replace the main PCB
P8	Protection for over high inlet/outlet water temperature difference in cooling mode	1) Inadequate water flow rate	1) Check that the water filter and water circuit are not blocked
		2) Inadequate inlet water temperature	2) Adjust the setting temperature to normal working range
		3) Main PCB damaged	3) Replace the main PCB
P9	Low pressure protection	1) Poor connection of pressure switch	2) Reconnect the switch
		2) Main PCB damaged	2) Replace the main PCB
PC	First step antifreeze protection in Winter Second step antifreeze protection in Winter	These functions occur when the ambient temperature is too low and the HPP is in standby mode	No action needed
PL	Water flow failure	1) Inadequate water flow	1) Check the water pump
		2) Water flow switch damaged	2) Replace water flow switch
		3) Main PCB damaged	3) Replace the main PCB
		4) Water inlet/outlet wrongly connected	Check water inlet/outlet connections
E3	Over high compressor exhaust gas temperature protection	1) Inadequate flow rate	1) Check the water pump and water control valve
		2) Water temperature setting too high	2) Lower the water temperature setting
		3) Poor connection of pressure switch	3) Reconnect the switch
		4) Main PCB damaged	4) Replace the main PCB
E4	High pressure protection	1) Inadequate flow rate	1) Check the water pump and water control valve
		2) Water temperature setting too high	2) Lower the water temperature setting
		3) Poor connection of pressure switch	3) Reconnect the switch
		4) Main PCB damaged	4) Replace the main PCB
E8	Communication failure	Failure of user interface	Check wiring connection between the PCB and the user interface

Technical data

SPECIFICATIONS	UNITS	HPP 6	HPP 8	HPP 12	HPP 15
Heat to water					
Ambient air 24°C, Water out at 27°C, 60% RH Capacity	kW	7.4	9.0	12.9	16.8
Power Input	kW	1.33	1.58	2.1	3.06
Coefficient of Performance	COP	5.59	5.72	6.14	5.49
Ambient air 15°C, Water out at 26°C, 70% RH Capacity					
Ambient air 15°C, Water out at 26°C, 70% RH Capacity	kW	6.0	7.3	10.0	13.9
Power Input	kW	1.32	1.54	2.04	3.05
Coefficient of Performance	COP	4.54	4.74	4.9	4.
Electrical data					
Power supply		220-240V 50Hz			
Maximum power input	kW	2.33	2.71	3.83	5.94
Maximum current	A	9.76	12.32	17.41	27
Maximum fuse size	A		16 Estimate	25 Estimate	40 Estimate
Compressor type		Rotary	Rotary	Rotary	Scroll
Air Data					
Nominal Air flow ± 10%	m ³ /h	2200	2000	3700	3800
Fan external resistance	Pa	30	37	39	40
Water Data					
Water flow ±10%	L/min	50	70	90	120
Pressure drop (water)	m hd				
Water connections	inches/mm	1 1/2 inches or 50mm			
Condensate water connections	inches	3/4"			
General data (hermetic system)					
Gas charge (R410a)	kg	1.00	1.45	1.85	2.0
Minimum Pressure	MPa	1.5			
Maximum Pressure	MPa	4.15			
Noise					
Noise	dB(A)	28	29	30	30
noise at 1m	dB(A)	<46	<47	<48	<48
noise at 10m	dB(A)	<28	<29	<30	<30
Water proof level		IPX4			
Dimensions					
Unit net dimensions	mm	968x654x405	968x654x405	1130x709x490	1130x709x490
Package dimensions	mm	1000x420x790	1000x405x780	1154x520x845	1154x520x845
Packaged weight	kg	58	53	72	93
Net weight	kg	51	60	79	100

Notes:

- 1 Allow 500mm clearance to service panels
2. Minimum air temperature -10°C
3. Water to have the correct balance pH 7.2 to 7.8, Free Chlorine 1.0 to 2.0 domestic, 3.0 to 6.0 commercial.
4. Dantherm reserves the right to change models without prior notice
5. R410a Global warming potential 2088

PARAMETER LIST

**The table below shows how the HPP has been preprogrammed
 These parameters should not be changed as they may cause the
 HPP to function incorrectly. If any of the settings have been**

Parameter checking.

Press the SET button for 10 seconds to enter the parameter checking interface, then press M to enter the parameter settings.

The parameters can be adjusted by pressing the ▲ or ▼ buttons.

Pressing the set button saves the change and switches to other parameter settings.

When in the parameter checking mode press the ▲ or ▼ button to exit parameter checking menu.

Parameters can be checked and adjusted when the HPP is in standby mode but parameters cannot be changed when the HPP is running.

Any changes to the parameters will not be saved if the power supply fails within 10 seconds of any adjustments.

Parameter list

No	Parameter name	Range	Setting
0	Memory function if power off	0 (no) 1 (yes)	1
1	Timer cycle	0 (once) 1 (every day)	1
2	X (Temp difference between inlet water temp and setting water temp to start compressor)	2-10°C	3
3	Y (Temp difference between inlet water temp and setting water temp to stop compressor)	0-3°	0
4	The interval for defrosting	30-90mins	40mins
5	Defrosting entry coil temperature	-30 - 0 (- and + are not displayed)	-7 (Displayed as 7)
6	Defrosting off coil temperature	2-30°C	20
7	Defrosting max duration	0-15mins	8mins
8	Compressor exhaust gas protection	90-120°C	118°C (Displayed as B8)
9	Setting temperature upper limit	40-65°C	40
10	Water pump running mode	0 (Special) 1 (Normal)	1
11	Pump-off time after reaching setting water temperature	3-20mins	15
12	Second anti-freezing mode	0 (heat pump) 1 (electric heater)	1
*13 See Note below	Unit mode selection	0 (cooling only) 1 (cooling and heating) 2 (heating only)	2
14	Inlet water temperature	-0-99°C	Actual temperature
15	Outlet water temperature	-0-99°C	Actual temperature
16	Coil temperature	-0-99°C	Actual temperature
17	Exhaust gas temperature	-0-127°C	Actual temperature
18	Ambient air temperature	-0-99°C	Actual temperature

Note

* Changing the value of parameter 13 from 2 to 0 changes the running mode of the HPP from water heating to water cooling.

The HPP is supplied as a pool water heater but is also able to cool the pool water.

The cooling mode is only recommended if ambient temperatures are likely to cause uncomfortably warm pool water temperatures.

When the HPP is in water cooling mode the maximum temperature the water can be cooled to is 28°C

Dimensions HPP Heat pump 6/8

Water Connections 1 1/2"
Female or 50mm
Condensate Connection
3/4"

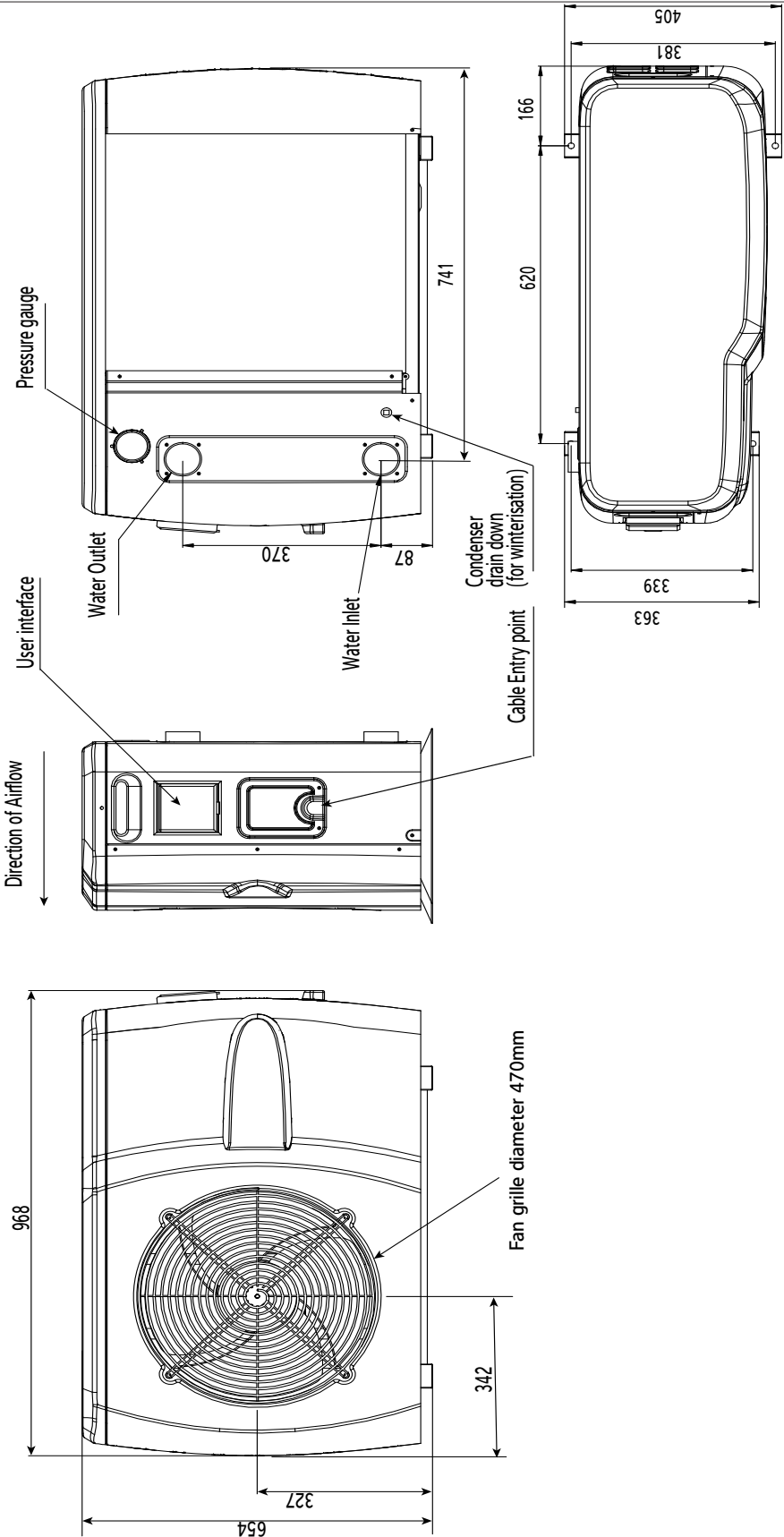

Dimensions HPP Heat pump 12/15

Water Connections 1 1/2"
Female or 50mm

Condensate Connection
3/4"

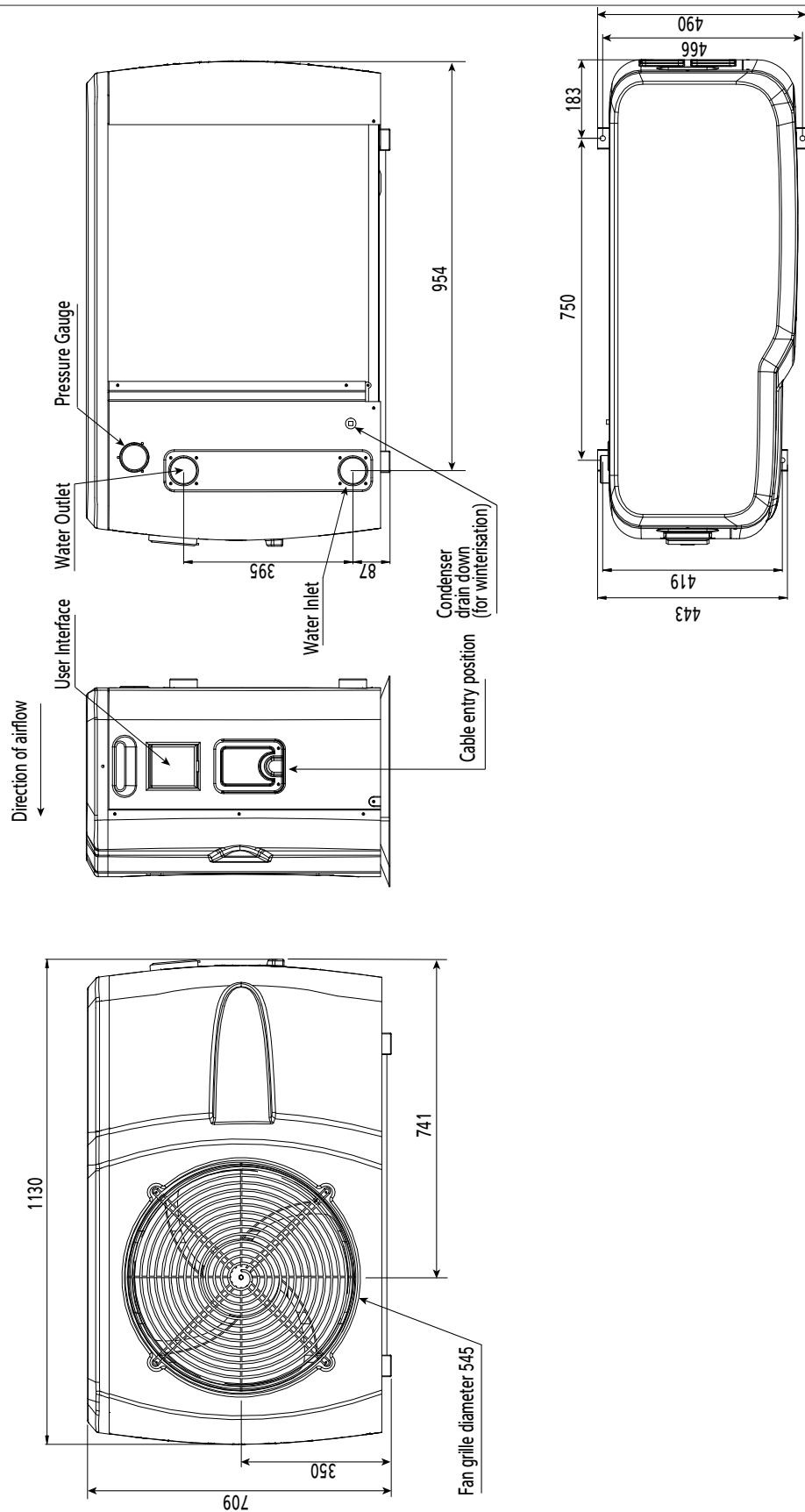

Winterisation procedure

WARNING. Isolate machine before removing covers!

The heat pump embodies electrical and rotational equipment, it is recommended for your own safety that a competent person carries out the following procedure.

ALL MODELS

Objective:

To provide frost protection
 To eliminate corrosion problems
 To inhibit electrical components

1. Switch off the electric supply to the heat pump.
2. Remove external fuses and keep in safe place away from heat pump to prevent accidental operation of heat pump.
3. Ensure that the water circulation pump is switched off.
4. Drain water from heat pump by:
 - a. removing the bung in the condenser drain system, labelled DRAIN (see dimension drawings for position of bung)
 - b. disconnecting pipework to and from heat pump
5. Flush through water circuit in heat pump by using CLEAN TAP WATER (NOT POOL WATER) via hose into outlet connection - run the hose for 10 minutes minimum; use spray nozzle if available.
6. Allow to drain - when drained, fit plastic bags secured by elastic bands over water connections.
7. Uncover electrical enclosure (see section 4.2) and liberally spray interior of unit, with moisture-repellant aerosol WD40 or similar; reseal enclosure.
8. If the heat pump is located outside, protect from weather by covering with VENTILATED cover. Do not use plastic sheet as condensation could occur within the unit. Optional covers are available from Dantherm.
 For HPP 6 and HPP 8 the part number for the cover is 1002770.
 For HPP 12 and HPP 15 the part number for the cover is 1002771.

Start up procedure after winterisation

1. Replace covers (if not fitted).
2. Remove front grille, using a soft brush, clean the finned surfaces of the evaporator. Replace panel.
3. Remove plastic covers on water connections and reconnect water piping or close drain valve.
4. Start up water circulating pump and leave running for at least 1/4 hour to establish flow and enable any air in piping to escape.
5. Replace fuses to heat pump circuit.
6. Switch on heat pump.
7. Check control thermostat is set to required pool temperature.
8. Check pool water daily to ensure it is at correct pH and has correct chemical balance. See PLUMBING Installation on page 7.

Warranty conditions

The following exclusions apply to the Warranty given by Dantherm A/S. No claims will be accepted if:

1. The heat pump is incorrectly sized for the application.
2. The heat pump is installed in any way that is not in accordance with the current procedures as defined by Dantherm A/S
3. The heat pump has been worked upon or is adjusted by anyone other than a person authorised to do so by Dantherm A/S
4. The air flow to and from the machine is outside the specified limits.
5. The water flow through the machine is outside the specified limits.
6. The heat pump has suffered frost damage.
7. The electrical supply is insufficient or in any way incorrect.
8. The fan amps and duct pressure are outside the specified limits.
9. The heat pump has not been maintained in accordance with service requirements in section 4.1.

Water Quality

Water quality

The correct combination of chemicals in a swimming pool is crucial, both for the health of users and for the inventory inside the pool room and the swimming pool's technical room. Insufficiently treated water results in poor hygiene, while water that has been excessively treated results in gases in the air that contain chlorine, which can irritate the eyes and cause breathing difficulties.

At the same time, the incorrect composition of chemical ingredients in the water can destroy all of the inventory in a very short space of time, including the heat pump and other equipment that have been installed to process the air.

Shown below are the threshold values, which apply to products for swimming pools. These threshold values must be complied with for the warranty to be valid.

Acidity pH	pH	7.2 - 7.8
Total Alkalinity, as CaCO ₃	ppm	80 - 120
Total Hardness, as CaCO ₃	ppm	150 - 250
Total Dissolved Solids	ppm	1000
Maximum Salt Content	ppm	35000
Free Chlorine Range	ppm	1 - 2 Domestic
Free Chlorine Range	ppm	3 - 6 Commercial
Superchlorination	max	30ppm for 24 hrs
Bromine	ppm	2 - 5
Baquacil	ppm	25 - 50
Ozone	ppm	0.9 Max
Maximum Copper Content	ppm	1
Aquamatic Ionic Purifier	ppm	2 Max

Exploded view

HPP Heat pump

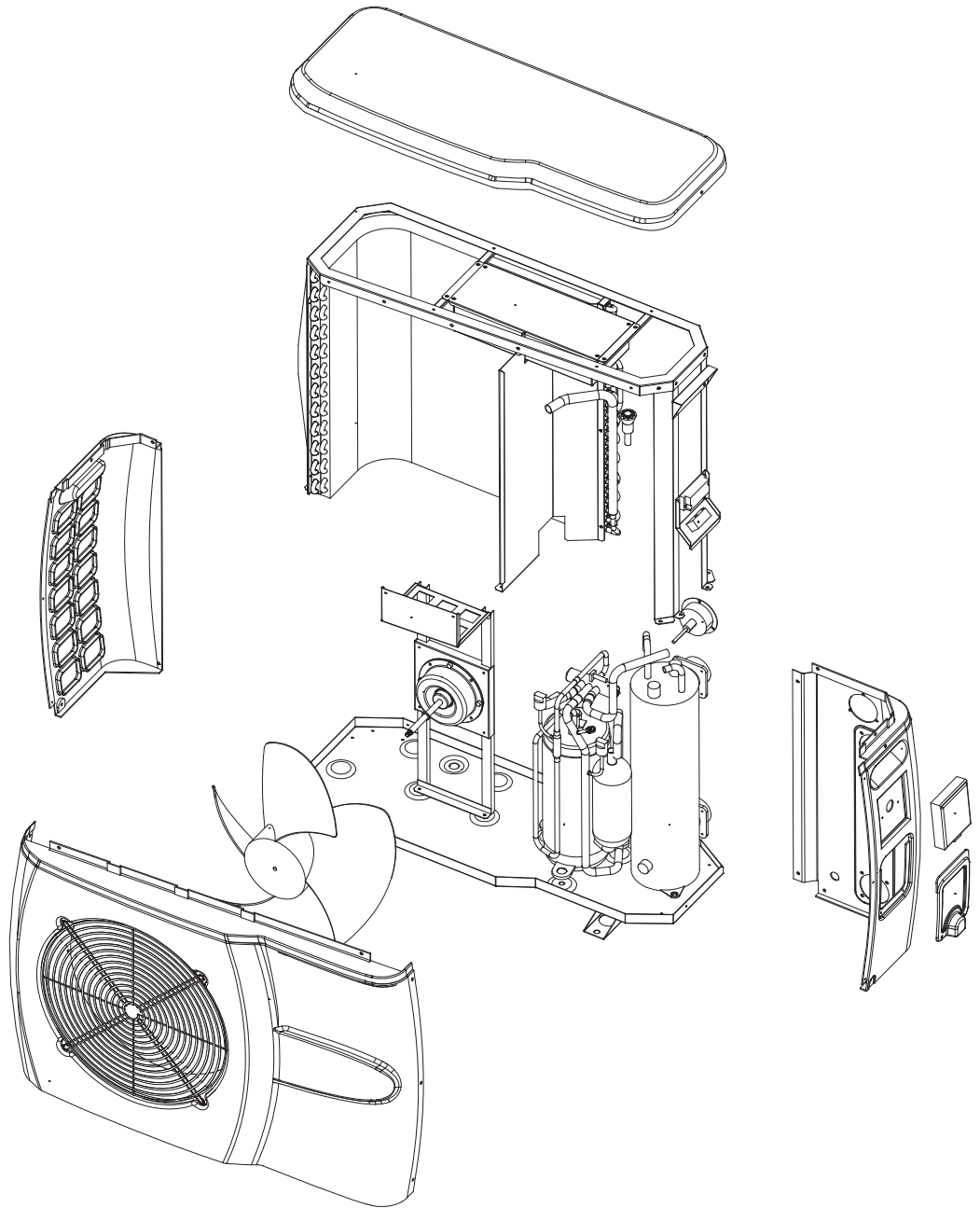

Dantherm A/S

Marienlystvej 65
 7800 Skive
 Denmark

Phone +45 96 14 37 00
 Fax +45 96 14 38 00

infodk@Dantherm.com
 www.Dantherm.com

Dantherm AS

Postboks 4, 3101 Tønsberg
 Norway
 Besøksadresse: Løkkeåsvn. 263138
 Skallestad

Phone +47 33 35 16 00
 Fax +47 33 38 51 91

Dantherm.no@Dantherm.com
 www.Dantherm.com

Dantherm AB

Fridhemsvägen 3
 602 13 Norrköping
 Sweden

Phone +46 (0) 111 930 40
 Fax +46 (0) 121 133 70

infose@Dantherm.com
 www.Dantherm.se

Dantherm

Suite # 1009 Prism Tower
 Business Bay
 Dubai, UAE

Mobile +971 56 831 7466
 Direct +45 60 23 55 29

frb@Dantherm.com
 www.Dantherm.com

Dantherm Limited

12 Windmill Business Park
 Windmill Road, Clevedon
 North Somerset, BS21 6SR
 England

Phone +44 (0)1275 87 68 51
 Fax +44 (0)1275 34 30 86

infouk@Dantherm.com
 www.Dantherm.co.uk

Dantherm Cooling GmbH

Ziegler Str. 19
 D-86199 Augsburg
 Deutschland

Direkt: +49 821 297 00 297
 Fax +49 821 297 00 298

KW@Dantherm.com
 www.Dantherm.com

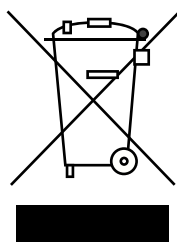

Dantherm can accept no responsibility for possible errors and changes.

Irrtümer und Änderungen vorbehalten.

Dantherm n'assume aucune responsabilité pour erreurs et modifications éventuelles.

Dantherm se exime de cualquier responsabilidad por errores y cambios realizados.

A Dantherm recusa qualquer responsabilidade relacionada com eventuais erros e alterações.

Компания Dantherm не принимает на себя ответственность за возможные ошибки и изменения в настоящем документе.